

: FOCUS OUR VISION FOR QUALITY



**SIMPLY RELIABLE,
SIMPLY EFFICIENT**
FOCUSING ON INCREASED QUALITY



Visit us online:
www.sickinsight-online.com

SUSTAINABLE SOLUTIONS FOR QUALITY AND MORE EFFICIEN



Dear Readers,

In industrial environments, capturing reality safely and reliably requires much more than just a vision.

We are using our sound knowledge of sensors and the industry to develop series products, systems, and services for vision applications. Our image processing solutions deliver innovation, quality, and lasting benefits. Mastery of not just a single technology but a broad portfolio of technologies designed with efficiency in mind provides the basis on which we are developing the right solutions for our customers' specific requirements and individual circumstances. We are currently a recognized partner to our customers in more than 40 key industries, spanning all possible areas of application for sensors.

SICK offers a broad spectrum of vision sensors, starting with compact devices that are easy to integrate, through configurable stand-alone solutions, and beyond to programmable high-speed cameras for the most demanding of requirements. The specially designed housings make for flexible mounting and are suitable for virtually any field of application. Automated setup functions and the intuitive user interface ensure straightforward commissioning. The SICK AppSpace eco-system delivers a high level of development flexibility to minimize complexity, costs, and risks in the implementation of customized image processing solutions. Essentially comprising the SICK AppStudio, an open application development system, and the programmable SICK sensors, SICK AppSpace is also available to our customers. It is used to create new solutions from both established SICK modules and integrable functions from various image processing libraries, such as HALCON or OpenCV, which provide the perfect match for customers' requirements and are compatible with tasks in the context of Industry 4.0. Such tasks include quality control, track and trace, object data capture, and predictive maintenance, for example.

In this issue of our customer magazine, we showcase the latest SICK solutions for high-quality and efficient production.

I wish you an informative and enjoyable reading.

Bösl

Reinhard Bösl
Member of the Executive Board of SICK AG



BETTER CY

08

A programmable camera for controlling robot arms and fingers
Sensor app allows for precision repeatability of robot arm positions during automated test cycles in the test labs at BSH Hausgeräte GmbH.



20

Sealed up tight?
The TriSpector1000 3D vision sensor checks the lids on jam jars and detects minor discrepancies in the surface of the lid.



Precision custody transfer measurement of natural gas

The new FLOWSIC600-XT gas flow meter conquers the demands of precision custody transfer measurement of natural gas.



Imprint

Issue 2/2016
 Publisher:
 SICK AG · P.O. Box 310 · 79177 Waldkirch, Germany
 Phone +49 7681 202-0
 Fax +49 7681 202-3863
 www.sick.com · editorial@sick.de
 Editorial team:
 Fabian Dörr (fd) · Solvejg Hannemann (sh) ·
 Michaela Karl (mk) · Tobias Maillard (tm) ·
 Stephanie Rott (ro) · Antje Stein (as)
 Layout:
 Daniel Kaidusch · Dennis Metzler ·
 Verena Weber
 Pictures:
 SICK AG · 123RF · Nencki AG
 Reproduction of individual articles is permitted
 with prior consent. Subject to change without
 notice.

CONTENTS

Discussion on reliable optical detection of real-time situations 04

BSH Hausgeräte GmbH:
 A programmable camera controls robot arms 08

All-in-one quality control solution for tire production 12

ZF: using 3D vision to check multi-disc clutches 14

Vision technology for track and trace at airports..... 16

3D vision technology for driver assistance at ports 18

Jam jars: 3D vision sensor inspects lids 20

Lipton: Inspector checks tea bag labels 23

Reading of Data Matrix codes on curved storage containers 24

3D monitoring for foils, tablets, and capsules 26

ABB: inspection of magnesium bricks 28

Inline quality control using turnkey vision solutions..... 30

GERRY WEBER: RFID systems provide added flexibility and high throughput 32

Lector Code Analytics detects poor print quality in good time..... 36

Detection quality: the key to quality control and process quality 38

Intelligent measurement technology for added quality at every stage of the process 40

Nencki: perfect precision on the test stand 42

Non-contact length and speed measuring for any material 45

Volume flow measurement using intelligent additional functions 46

New master plan for mercury emissions from large combustion plants 48

Emissions measurement for electric arc furnaces 50

Custody transfer measurement of natural gas 52



INTERVIEW WITH ANDREAS BEHRENS AND DETLEF DEUIL

PROGRAMMED FOR CUSTOMER APPLICATIONS

SICK has over 30 years of experience in the field of vision technology and continues to incorporate new innovative and intelligent solutions for identification, positioning, detection, inspection, and quality control into its area of expertise. The technical experts at SICK have created an extensive and, above all, scalable portfolio of 2D and 3D vision sensors. SICKinsight spoke to Andreas Behrens, the Head of Marketing & Sales (bar code and RFID vision) at SICK AG, and Detlef Deuil, the Head of Product Management for Vertical Integration Products at SICK AG, about the ways to achieve reliable optical detection of real-time situations in industrial environments and dimensions in which this is possible.

SICKinsight: SICK offers a wide range of configurable and programmable vision sensors. What are the latest innovations in the area of 2D sensors?

A. Behrens: Let's start by taking a look at 2D codes. With the Lector63x, we have a configurable 2D vision sensor that fits in perfectly with the rest of our product portfolio. It sits exactly between the renowned Lector62x in the compact class, which is particularly well suited to smaller workspaces and shorter distances, and the high-performance Lector65x code reader for huge working environments and long distances, as is the case in logistics applications, for instance. In this case, we are aiming precisely at this middle ground by offering a complete new Lector® series and, at the same time, making the optical concept even more flexible. The aim of the Lector63x is to achieve added variability. Users can use both C-mount and S-mount lenses and, as a result, achieve flexibility for responding to various working environments and reading distances.

SICKinsight: Do you have any examples of what these solutions might look like?

A. Behrens: The Lector63x can be used in areas where you need to do more than just identify and track individual products. Products can also be packaged and combined to make batches. This combination means that the system has to read an increasing number of codes at once. In larger applications, the Lector65x can even build on this. In both the logistics industry and in manufacturing facilities, we have come across logging stations where products from the Lector® series are installed as presentation cameras. Simply guiding the objects past the device by hand enables their codes and corresponding object information to be read and logged in the higher-level ERP system.

D. Deuil: In addition, we offer a further advancement in the area of decoding hard-to-read codes. We have noticed that cost pressure plays a major role in industry. This has led to poorer print quality in codes because, for example,

they are printed straight onto the cardboard instead of onto a label. This in turn increases demands on the read devices. Thanks to the Lector Code Analytics function, we are able to generate things known as preventive maintenance events for this purpose. For instance, the device will automatically detect if a printer's print quality declines along a line, meaning that codes will soon start becoming impossible to read.

SICKinsight: Not only is this going to be of interest for the logistics industry, it will also certainly appeal to the packaging industry.

D. Deuil: That's right. And we are also tapping into another important field in the packaging industry. Here, we are looking at the identification of expiry dates; in other words, reading plain text. Until now, only our Lector620 OCR 2D vision sensor (OCR stands for optical character recognition) could detect plain text, though this was restricted to a limited image field. The market itself has special requirements when it comes to

tolerances, print quality, orientation, and large working ranges. Say, for example, we had a production line for filling drinks packages. The packages are transported on conveyor belts that vibrate, causing everything to shake. In this case, you would need a good knowledge of image processing to make sure the codes can be read clearly from the vibrating drinks packages. On the basis of feedback from the market, we have added the OCR function to the entire Lector® series. This allows us to offer customers a full product portfolio that also covers various price categories. And we aren't talking about the classic method using programmable cameras; we have created a solution that our customers can configure. In doing so, we have translated the ease of commissioning and calibrating the device (a hallmark of image-based code readers like the Lector) into the world of OCR.

SICKinsight: Do any other SICK product families in the field 2D vision feature a similar form of continuity?

D. Deuil: From the Inspector I20 to the Inspector PIM60, our Inspector product family of configurable 2D vision sensors has been very well received in industry. On the one hand, the Inspector impresses users with its simple commissioning process and wide array of application possibilities. On the other hand, its hardware is exceptionally rugged thanks to its industry-ready SICK design while its software is extremely reliable thanks to highly effective and trustworthy image processing algorithms. Building on this, we are also planning to establish programmable versions of the Inspector product family on the market, the Inspector P-series.

SICKinsight: Does this mean we are seeing a shift from configurable sensor technology towards programmable products?

A. Behrens: No. After all, configurable sensors are quick and easy to set up. It is precisely this idea that we are putting out there to make sure our customers continue to see us as a reliable provider of configurable solutions. However, a configurable product becomes increasingly

complicated with every new function added while every configuration comes with new switches and slide controls for the user to figure out. With the programmable version of the Inspector, we want to make the world of configuration a little bit easier so that customers can program their own devices. The programmable Inspector comes with all the relevant basic functions. After all, programmable doesn't mean that customers have to write their own program from scratch. Instead, they can start from a specified level and go from there, especially when it comes to dealing with the user interface.

SICKinsight: And how will customers deal with this? Don't they need advanced knowledge?

A. Behrens: SICK can provide support in this area. Developed primarily with system integrators and OEMs in mind, we have created SICK AppSpace, an eco-system (as it is known in IT world) that aims to provide users with the space they need

for their own ideas. They can use this space to create their own apps as a way of enhancing our hardware. For this purpose, we offer users a complete framework, including a development environment, and can even provide full turnkey solutions for a number of functions. This takes a great deal of complexity away for the user. Where we used to need a wide range of configuration settings for various groups of end users, you can now develop a specific solution for just one end user. As a result, system integrators and OEMs can develop customer-specific applications and only need to deal with the last 10% of the programming work. With SICK AppSpace, we therefore also offer customers the chance to use around 2,000 pre-programmed functions from the renowned HALCON image processing library, which has already been launched on the market by the software manufacturer MVTec. By breaking open an existing solution space and expanding it, we can now offer significantly more application options.

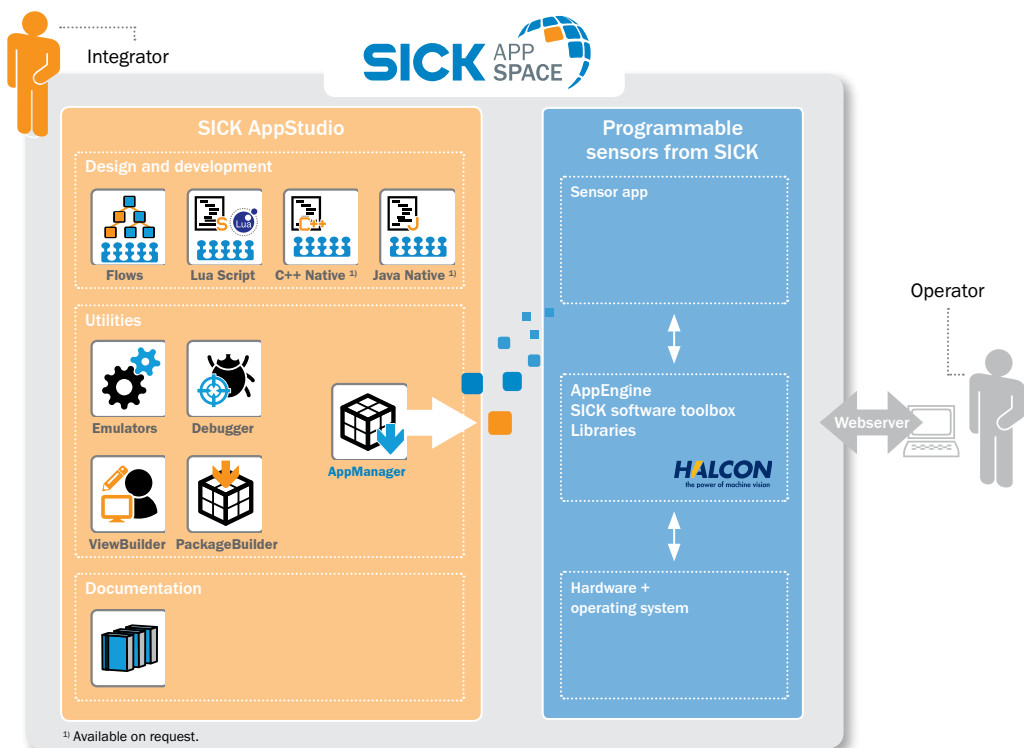

SICK AppSpace architecture.



Simple, multi-technology sensor integration with the SIM4000 Sensor Integration Machine.

SICKinsight: Seeing as we are talking about SICK AppSpace, are you implying that technology might also move toward the area of sensor apps?

D. Deuil: This is one area that we will be pursuing to make sure we can provide both our development-based customers as well as our end customers with ready-to-use sensor apps. In this case, a sensor app is not the same as an app that you would get on your smartphone. The aim of a sensor app is to provide a solution for one specific customer application. When creating the AppSpace architecture, we attached importance to making sure that an app created for, say, a matrix camera would also be able to run on another sensor regardless of the hardware used and depending on the functionality. Ultimately, SICK AppSpace gives developers the chance to write their own custom-de-

signed apps. Of course, applications, by definition, mean that additional data will be generated. Particularly in the area of quality control, this data can be used for further process analyses later down the line so that users can optimize their workflows or even generate preventive maintenance events.

SICKinsight: What is happening in terms of data protection?

D. Deuil: Thinking about sensor apps like this, each app will of course have its own encryption process. This is linked to a company ID for the developer's place of work. The developer can then decide to make the app public or to press a button to lock the app. In the latter case, only the developer is able to open the app again. This is a safe solution based on the latest standard of technology.

SICKinsight: What happens if a developer has any questions or issues when working in SICK AppSpace?

D. Deuil: SICK AppSpace has been created for developers by developers and has been set up with the intention of forming the basis for an eco-system. In an eco-system like this, the main aim is to enhance one another's expertise; in this case, it would be for the field of software. Our idea is to build up a community for this purpose. To promote the mutual exchange of experience and information, we are planning to form the SICK AppSpace Developers Club. A special portal will also provide support, allowing users to create online tickets for problems, use blogging functions, watch tutorials, and read about certain development issues in documentation.

SICKinsight: All of this will surely spread beyond the area of vision sensor technology, right?

A. Behrens: That's right. At the end of the day, we are helping our customers to improve their quality standards. To do this, we are providing them with solution spaces that allow them to tailor our solutions to their own requirements and goals. As a result, you will get solutions that are less complex and that certainly will involve more than just vision sensors in some cases. That is why SICK is planning to expand the new product field of Vertical Integration Products, under the guidance of Detlef Deuil.

D. Deuil: We are aiming to make sure that this free solution space is not only limited to the area of 2D. What we really want is to expand across an entire area of technology, in other words moving into 3D and other types of technology. To achieve this, we have developed SIM technology, which is currently the only technology of its type on the market.

SICKinsight: You are referring to the new Sensor Integration Machine from SICK, the SIM4000. What is it that makes this technology so unique at the moment?

D. Deuil: The SIM4000 Sensor Integration Machine allows for simple, multi-technology sensor integration via IO-Link and can be used with sensors for distance and height measurement, for instance, or for volume detection. For object detection, we are able to combine cameras with light grids or camera data with distance sensors. As a result, we are theoretically able to see a wide range of objects through new eyes. On a horizontal level, we can combine lots of sensor data into a point cloud and can even apply complicated image processing algorithms, such as fusing 2D or 3D sources. That is because the device is a freely programmable multi-camera and sensor processor that does not require any prior knowledge. Users can program a wide assortment of applications using the SICK AppSpace and the built-in HALCON image processing library as a basis.

SICKinsight: So the launch of the SIM4000 means that SICK is providing users with intelligent (or in other words, pre-processed) sensor data, quite in keeping with the concept of SICK Sensor Intelligence.

D. Deuil: The Sensor Integration Machine is a sort of data collector and image processor for Industry 4.0. Before I can archive any information and start analysis, I first have to collect all of the object data. I have to be able to conduct right to left comparisons. Essentially, we should also see ourselves as a SICK sensor intelligence data provider.

SICKinsight: Let's go back to the 3D solution space for a moment. When we discussed the 2D vision portfolio, you mentioned the benefits of configurable sensors. Is configurability also an issue for the field of 3D?

A. Behrens: For simple 3D image processing, we have the programmable IVC-3D camera. Now, SICK has its first configurable 3D vision sensors, like the TriSpector1000. In terms of its basic technology, this sensor is very similar to the Inspector 2D vision sensor. It has exactly the same tools, like the object locator, but these have simply been adapted for the 3D range. The TriSpector1000 is in the same configuration landscape. This offers a bit of extra freedom as to whether I solve a problem using 2D or 3D technology and always depends on the application in question. The TriSpector1000 comes with tools that allow it to inspect an object at a certain point with accurate and millimeter precision. Because the TriSpector1000 is a classic sensor, I always end up with one switching signal that I can use to make a yes or no decision. I can either send the result to the switching outputs or transmit it over a network. Using the sensor is actually really easy for anyone who has already worked with 2D vision sensors from SICK. They just have to get used to thinking in 3D to begin with.

SICKinsight: What are benefits of an additional height coordinate in measure-

ment applications or in tasks such as quality and completeness checks and part position detection?

A. Behrens: Of course, this would be a volume measurement, as used in the food industry, for example. But this takes it even further. With the TriSpector1000 3D vision sensor, you always work with one laser line, concentrating solely on the height line which is used for the inspection. 3D therefore offers a clear result, even in relation to light. When working with 2D sensors, we have come across cases where the sunlight has suddenly become so bright that the object is no longer visible, for instance, or the sensor can't detect an edge. Or there are cases where other external factors cause additional reflections and disrupt the object detection process. With 3D solutions, we can get rid of the majority of these ambiguous results and achieve a higher level of solution security.

D. Deuil: Type of industry is a key concept here. In the area of 3D, we offer streaming cameras with a wide array of image generation options for permanent data capturing. The images are then processed on a PC. To deal with high-speed height and volume measurements in quality and shape checks, we can offer customers our Ranger product family. For use in harsh environments, we have the Ruler product family, with the ScanningRuler being particularly well-suited to robot-aided gripping applications. We recently launched the Visionary-T with 3D snapshot technology for indoor use in intralogistics, robotics, or in industrial vehicles, and the Visionary-B with 3D snapshot technology as a plug and play solution for outdoor commercial vehicles. There are also two new 2D streaming cameras available on the market: The rugged midiCam and the ultra-compact picoCam, both of which allow for speedy plug and play installation on the SIM4000 Sensor Integration Machine we spoke about earlier and, as a result, also help to tap into new solution spaces.

SICKinsight: Thank you both for taking the time to talk to us.



A PROGRAMMABLE SICK CAMERA CONTROLS ROBOT ARMS AND FINGERS

FOR THE RIGHT AMOUNT OF FINGERTIP PRECISION

At the test labs in one of the world's largest and most cutting-edge dishwasher factories, BSH Hausgeräte GmbH has invested in a fully automated robot to conduct lifecycle tests on dishwasher panels. This robot is actively controlled by a programmable camera. The robot takes over all aspects of operating the machine, relieving strain from the testing team.

>> Dishwashers are some of the most traditional kitchen and household appliances in Germany. In 2015, 63% of all households had a dishwasher. Newer models are adapting to trends in the world of kitchen design in terms of their functionality and appearance. Changes to the design also require production parameters to be adjusted and can also affect factors such as quality control.

Touchpads replace buttons

The latest generation of BSH dishwashers do not come with conventional control panels and moving pushbuttons. Instead, they are equipped with a printed thin-film transistor (TFT) display. To operate the dishwasher, all you have to do is

touch one of the program icons on the display. To make sure the control panels work reliably throughout their entire service life, the company had to develop innovative lifecycle tests for the pilot series of the panels, during which they pass through hundreds of demanding test cycles. To make things easier for the testing staff, BSH is using a new mobile robot system that tests the usability of the machines' panels in complete test cycles.

Test lab for conducting lifecycle tests on dishwasher control panels

"The lab for testing the service life of dishwasher control panels needs to be equipped with a wide array of technol-

ogy, including solutions for operating certain keys. For this, we need to use a new type of technology based on touch sensors. In this area, it is very important to make sure that the key is positioned with accuracy and precision that allows for repeatability," explains Hans Peter Maurer, the Head of Testing, Quality Management, Product Division Dish Care at BSH, describing the challenges the team faced.

"We want to measure the signals emitted while the key is activated with a very high level of accuracy. We are keen to find out whether these indicators actually change during the machine's service life and beyond. In light of this aim, we have to keep the influencing parameters

generated during testing as low as possible and the precise positioning of the activating element is one very important parameter.”

In its role as the integrator, the company *attentra* from Tübingen in Germany opted for the new programmable 2D Inspector P65x camera by SICK and then programmed a suitable piece of application software (sensor app). Specializing in vision technology, *attentra* develops end-to-end solutions for in-

dustrial image processing and industrial automation.

A solution using a programmable camera

“The robot was already set up. We simply programmed the sensor app in a way that allows the camera to use a recurring feature to find the control panel in the space. In this case, we were able to identify a very good and very stable feature for image processing. We can then use this feature to determine the position

where the keys are located. This means we capture an image: The app conducts its search and measures the position. It then sends the resulting offset values to the robot, which moves to the point in question with full repeatability. This process saves having to attach a feature to the panel,” explains Christian Vollrath, Managing Director at *attentra* GmbH.

The test system has enough capacity for 16 control panels. The robot then deals with these 16 panels automatically.



Test lab for conducting lifecycle tests on dishwasher control panels: Mobile robot system conducts entire test cycles.



The robot uses the testing fingers on its arm to check each individual key on the dishwasher control panel.

The testing process

When new control panels or variants are available for testing, they are first mounted individually into the testing slots before being connected to a laptop. The operator then selects the panel variant on the robot's control panel and adjusts any necessary settings. This makes sure that the robot knows where the keys on the panel variant are located. Once the test process has started, the robot guides the camera to the first reference position, where it takes a picture, determines the position data of the symbol detected, and then sends this data to the robot control unit. This actively brings the robot arm in line with the reference picture so that it sits directly over the center of the image. The robot now uses the testing fingers on its arm to check each individual key. On the laptop screen, the user sees the current image from the camera, with a green symbol indicating that the reference feature has been detected correctly. Once all of the keys on a panel have been tested, the robot moves the camera to the next panel and the process starts from the beginning again

“It is also important to note that precision has increased enormously as a result of using the camera. We would never have achieved this when judging by eye or using a mechanical system.”

Hans Peter Maurer, Head of Testing, Quality Management, Product Division Dish Care at BSH

with the search for and evaluation of the reference feature.

Prior to series approval, up to 50 panels from a single variant can therefore be tested and subjected to statistical analyses until the variant can finally be approved.

For faster thorough checks related to the expected product service life, the testing department uses accelerating influences, such as temperature or moisture, to subject the components to a certain level of load.

“The InspectorP65x camera brings the robot arm and testing fingers perfectly in line with the control panel so that our testing fingers hit the individual keys with accuracy. One benefit of the InspectorP65x is that it actively controls our robot and can run all night long. This means that the camera helps to increase efficiency and throughput enormously. It is also important to note that precision has increased enormously as a result of using the camera. We would never have achieved this when judging by eye or using a mechanical system,” sums up Hans Peter Maurer.



SICK AppSpace for tailor-made application solutions

The programmable InspectorP65x camera is part of the innovative eco-system, SICK AppSpace, which is made up of programmable sensors, cameras, other programmable products, and a software platform. The high image resolution, the compact housing, exchangeable optics, and a choice of illumination make the InspectorP65x the ideal combination of performance and flexibility. With the HALCON image processing library, installed as standard, even the most challenging application demands can be met. Users do not need to worry about acquiring a runtime license as it is included with the InspectorP65x as standard. An integrated web server makes it possible to visualize a graphical user interface on any browser-compatible display device.

The built-in App Engine is the only thing needed to ensure that all SICK AppSpace-compatible devices can be programmed. The software development kit SICK AppStudio is used to develop customer-specific application programs on a PC. When it comes to creating sensor apps, users can use programming technology such as graphical flow editors, Lua script programming, and the options of C++ or Java programming. HALCON image processing procedures can also be integrated. Helpful tools such as emulators, debuggers, resource monitors, and an extensive range of documentation and demo apps make the development process easy. The user interface for machine operators can be created individually as a web GUI using the graphical ViewBuilder. The Package-Builder combines all the software components to make a single package that safely defines access rights.

The shared development environment needed to create a wide range of SICK

products provides a high level of investment security. Because the sensor apps can be reused on various programmable sensors, the amount of development work needed is reduced. Furthermore, existing solutions can be adjusted to future tasks on site at a later date.

And there's more...

The SIM4000 Sensor Integration Machine – part of the SICK AppSpace eco-system – is also opening up new opportunities for application solutions. Data from sensors and cameras from SICK can be merged into a point cloud, evaluated, archived, and transmitted. 8-gigabit Ethernet interfaces are available for 2D or 3D cameras, and in some cases fea-

ture power over Ethernet (PoE). Sensors can be integrated via IO-Link for distance and height measuring purposes. Thanks to the high-performance multi-core processor featuring hardware support, the SIM4000 enables image preprocessing and handling of input and output signals in real time. The integrated HALCON library also makes it possible to find solutions for sophisticated image processing tasks. (as)



Find out more about BSH at:
www.bsh-group.com

Find out more about attentra at:
www.attentra.de/en/



The programmable 2D InspectorP65x camera actively controls the robot arm.

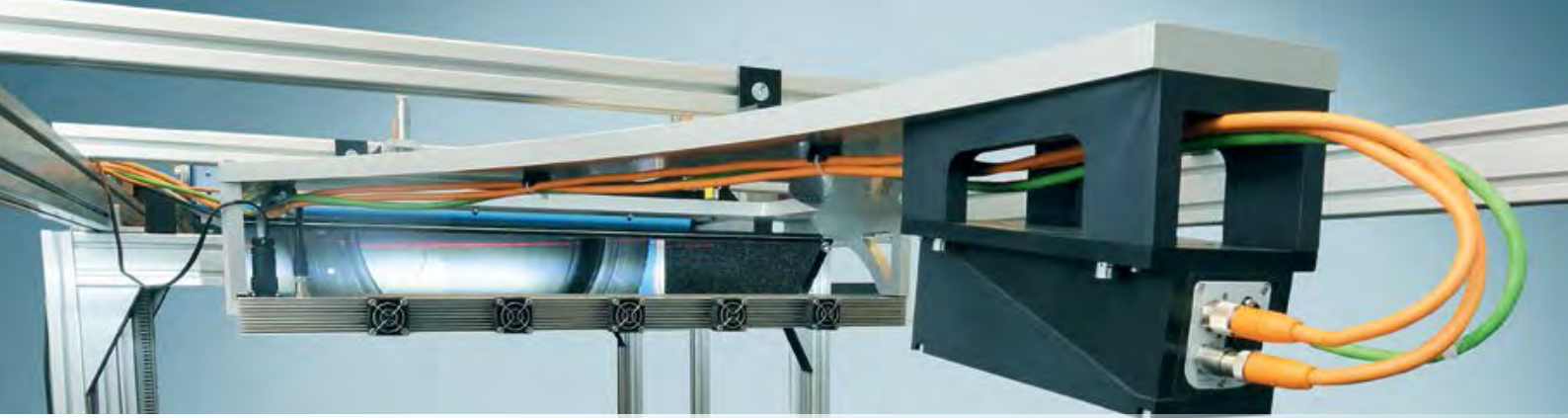

ALL-IN-ONE QUALITY CONTROL SOLUTION FOR TIRE PRODUCTION

POWERFUL IMAGE PROCESSING: FOR ADDED QUALITY AND ADDED EFFICIENCY

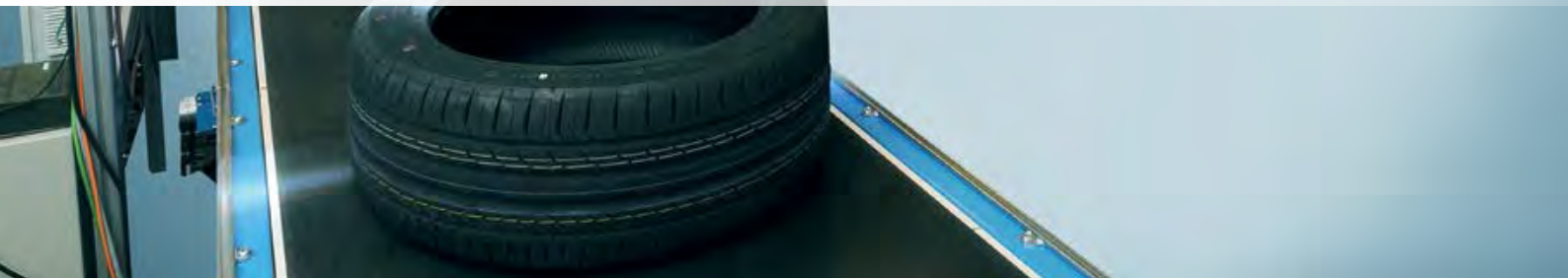

Manufacturing a tire requires over one hundred individual steps and a wide array of components – a complex process with high standards when it comes to quality and safety. Careful testing is absolutely essential as any undetected quality issues often result in complaints – which in turn result in added costs and potential damage to the tire manufacturer’s image. Thanks to powerful, industrial image processing technology in the form of IRIS-M, SICK offers companies a tailor-made system solution for designing cost-efficient quality control processes.

>> The more aspects of the complex tire manufacturing process that are monitored, the easier it is to guarantee the quality of the final product. Using manual monitoring for this purpose not only takes more time, it is also unreliable. Quality control systems based on powerful, industrial image processing can deliver reliable results. IRIS-M has been specially developed for this demanding task and is able to process both colors and 3D information. This data delivers reliable information about the shape and position of the tire – regardless of the characteristics of the background. This information is used to calculate something known as a “region of interest,” in which the system looks for markers. As a result, the system only evaluates markers that are actually on the tire. The main purpose of checks is to find out if any marks are damaged or missing completely. Color components also have to be identified and classified clearly. IRIS-M allows the individual markers to

be evaluated – which markers are still valid and which ones are not.

Modular, pre-calibrated, user-friendly

Depending on the requirements, the IRIS-M can consist of up to three standardized modules: Two identical modules – installed on top of and underneath the conveying system – detect and validate color markers and adhesive markers. The third “line module” is installed to the side of the conveying system and identifies the colored marks on the tires’ tread. All of the modules’ components (including the camera, laser, illumination, and mirror) are already calibrated upon delivery, based on the customer’s specifications. To take high availability requirements into account, the IRIS-M is equipped with a comprehensive range of diagnosis options and a self-test function. As soon as one of the components has to be cleaned or re-calibrated, a notification appears so that maintenance work can be organized in good time.

Image processing for complex vision solutions

In addition to powerful vision components (the ColorRanger E streaming camera forms the heart of the system), the IRIS-M quality control system is also equipped with its own powerful image processing software, which is based on the HALCON image processing library. Because the system is required to clearly determine both the individual marks on

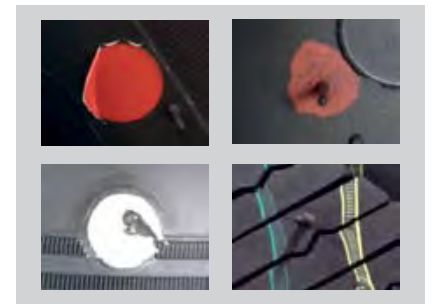

Red is not always red: One big challenge during image processing is identifying and validating various colored marks.

MODULE

Identifies and validates colored markers and adhesive markers

1



MODULE

Identifies and validates colored markers and adhesive markers

2

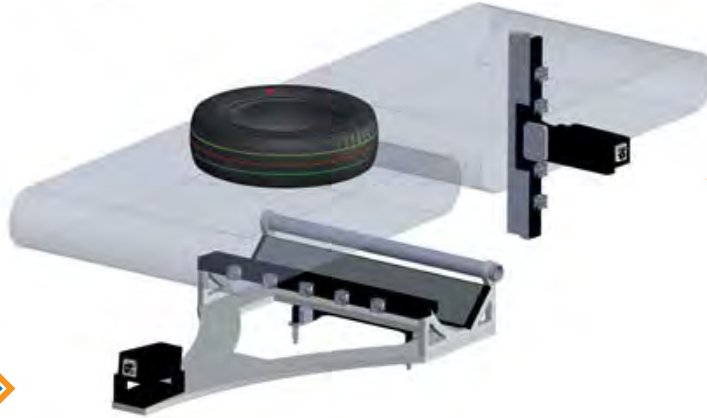

LINE MODULE

Identifies the colored markers on the tires' treads

3

Whether it is identifying markers and/or marks on the tires' treads, the IRIS-M can consist of up to 3 modules, depending on the requirements for the task at hand.

the tire and their colors, the software has to deal with quite a complex challenge. This is because the color markings attached during the manufacturing process may change while the tire is in the curing press. Adhesive markers, on the other hand, are attached after the production process and can therefore be partially or even completely damaged during transportation. When identifying the marks on the tires' treads, potential color deviations may also play an import-

ant role. Thanks to its powerful image processing capacity, the IRIS-M can classify so-called "color areas" and can also clearly assign any deviations to a color. Though it may be easy to the human eye, the IRIS-M has to use intelligent software algorithms for this task.

Scalable complete solution

Products, system knowledge, and years of experience in solving complex vision applications: With the IRIS-M, SICK

brings all of this together to provide a scalable end-to-end solution for tire marking quality control. As well as a high level of performance, SICK also focuses on factors such as good cost efficiency and easy commissioning – important features for the wide acceptance and use of the system by international companies. (tm)

Pin Inspector: one system, two quality checks

Plug connectors and printed circuit boards are some of the most cost-efficient electronic components – nevertheless, errors during the manufacturing and mounting of the components can have a huge impact. The Pin Inspector quality control system is based on the Ranger streaming camera and reliably checks that printed circuit board pins are in the right position before being pressed. Following the pressing process, the Pin Inspector checks the height of the pins. This information can be used to determine whether the pins have been pressed correctly onto the printed circuit board. This solution can also be used to monitor individual plug connectors. Are all the pins in place? Have any of the pins been bent or broken off? Pin Inspector therefore offers two separate quality checks in a single system, which allows for easy modification and speedy integration into existing plants.



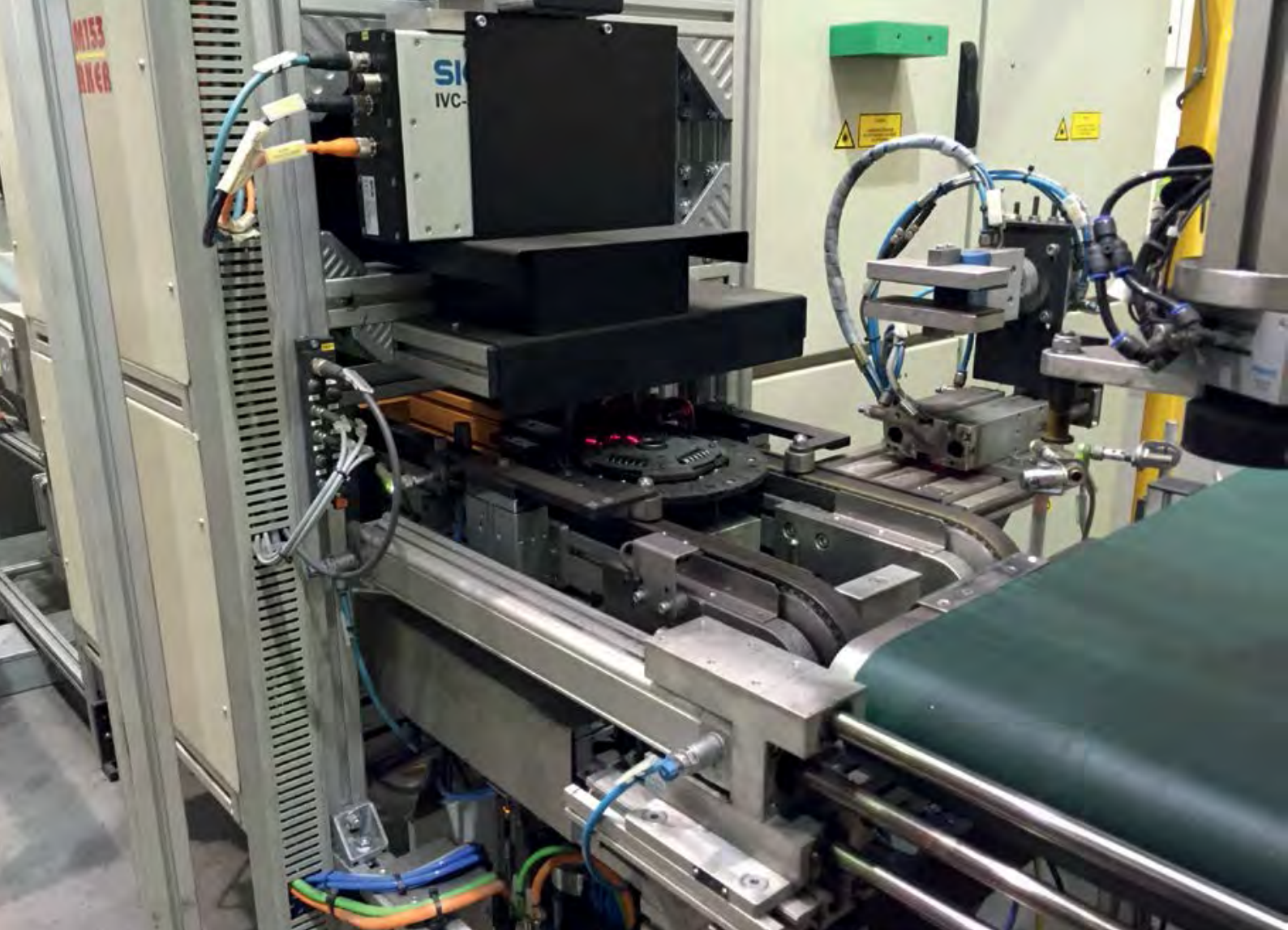

MONITORING OF CLUTCH DISCS AT AUTOMOBILE SUPPLIER ZF

THREE-DIMENSIONAL INSPECTION WITH 360° ROTATION

A wide range of industrial applications in nearly all industries can be covered with 3D vision sensors. While 2D vision sensors only measure the x- and y-axes of an object, 3D vision sensors are also designed to measure the z-axis. For this reason, ZF Slovakia decided to use the IVC-3D vision sensor from SICK in a successful application for monitoring clutch discs.

>> ZF Slovakia is a subsidiary of the ZF Friedrichshafen AG Group. In 1915, Ferdinand von Zeppelin founded the company with the original plan of supplying gears for airships and motor vehicles. Today, ZF is one of the three largest automobile suppliers in the world. At the Trnava factory in Slovakia, components for power trains are produced. One part of the power train, the clutch disc, contains several rivets and springs which a

machine operator inspected formerly. Quality control in the assembly line consisted of measuring rivet height, cladding and the parallelism of the springs. However, there were seldom complaints concerning a specific point where visual inspection proved to be very difficult. That is why ZF Slovakia and SICK spol. s r.o. decided to go for an automatic solution for clutch disc monitoring, which was aimed to increase efficiency in pro-

duction and at the same time to control quality of the parts.

Product-specific 3D measurement

The IVC-3D vision sensor from SICK, which was selected for this application, is capable of detecting the object in the assembly line, even if it is rotating around its own axis. When recording, no start position is defined and the IVC-3D automatically measures the part. The result is a

processed 3D scan where visualization is generated from a computer according to the specific customer requirements. Since a total of five clutch disc types need inspection, the program offers the option of selecting the product type. At the same time, minimum and maximum limit values can be set for every type. Every single disc goes through 32 checks, and the entire test cycle lasts 5 seconds. The evaluation time is less than a second. The results of the scanning process are sent to the computer, where either a green signal displays if the disc is OK, or a red signal displays if the disc is NOK. In this case, production is stopped and the operator needs to take the defective part off the assembly line.

ZF Slovakia chooses sensor technology from SICK

ZF Slovakia is very pleased with the quality control solution provided by SICK. A thorough and reliable clutch disc monitoring system has been realized with the use of IVC-3D vision sensors, and it allows inspection of up to 5,400 discs a day. This means ZF Slovakia saves time and money and has less machine downtime. ZF Slovakia has also chosen

to use SICK sensor technology for other applications where the discs are not rotating. The IVC-3D detects the strip in the clutch disc center while it moves on the

conveyor belt. With all these applications the company ZF Slovakia proves that production of first-class products is one of their main priorities. (ro)



Using the IVC-3D vision sensor to monitor quality in multi-disc clutches.

THE PERFECT TECHNOLOGY FOR TRACK AND TRACE SYSTEMS

RELIABLE TECHNOLOGY FOR THE FUTURE OF TRACKING FLIGHT BAGGAGE



Rising passenger figures and increasing RPK (revenue passenger kilometers, in other words the number of kilometers traveled by revenue-paying passengers): a major challenge for airlines, ground handlers, airport operators, and baggage handling system operators. After all, more passengers also means more baggage which has to be logged, sorted, and traced. If the right track and trace systems and suitable identification technology are employed, operators can achieve reliable identification and, as a result, high throughput.

>> Airport operators have been using one of the most popular forms of track and trace systems for airport baggage since 1993: the Airport Luggage Identification System (ALIS) by SICK. ALIS' built-in bar code scanner achieves very high read rates, guaranteeing the seamless transportation of baggage along conveyor systems that stretch for several miles. In addition to extensive application knowledge and SICK's global presence, the reliable identification of bags also plays a decisive role. Demands on the bar code scanner's read performance are also rising at a continuous rate, as an increasing number of passengers are checking in online and printing their own baggage labels at home. This can cause the quality of labels to deteriorate. Furthermore, the position of the label on the bag along with the shape and properties of the indi-

vidual labels can vary significantly when viewed from a global perspective.

No Read and No BSM: The bar code is not the only key factor

The read performance for transfer lines – where the baggage in the baggage handling system is transported from one airplane to another – tends to be lower than in bag drop lines. This is mainly due to damaged or contaminated labels. If this results in the system being unable to read the bar codes on the labels (No Read), the bag in question cannot be assigned to its unique Baggage Source Message (BSM). This data set (which is internationally valid) is stored in databases and contains the information needed to sort the bag (flight number, IATA code, etc.). Another challenge for airport operators: Sometimes complete BSM data sets

go missing or the link to the database is interrupted or even down on a long-term basis (No BSM). In these cases, the bag cannot be sorted even though the bar code has been read correctly.

In both cases (No Read and No BSM), the bags have to be transported to something known as the MES (the manual encoding station), where they are identified manually – which has a negative impact on throughput and the bag's transfer time. This can lead to delays. In the worst case scenario, the bags are left behind and the airport operators and airlines have to face higher costs and damage to their reputation.

Integrating the right technology

SICK's track and trace systems are available for integration into various forms

of identification technology. For airport baggage identification, vision technology using the Lector65x image-based code readers offers a number of benefits. The primary advantage is a significant increase to the bar code read performance. The amount of work needed for alteration is small: The Lector65x can be installed easily into existing frames without needing to change communication with the control unit.

Furthermore, the image-based code readers provide high-resolution images that can be used for video coding and optical character recognition (OCR). For example, they can use the label to automatically read the BSM information needed for sorting. A further benefit provided by vision technology: An increasing number of high-resolution images are available for each bag. Because the bag passes below several cameras on the conveyor belt, each image is photographed from a different perspective. Overall, you end up with a series of images of the same bag from various different perspectives, improving identification of the bag.

Vision technology can also be integrated into a laser-based ALIS system and be retrofitted – all with very little effort. The outcome? An ALIS vision system based on the Lector65x.

One system solution, lots of applications

When it comes to achieving the best possible read performance, selecting the right type of identification technology plays an important role, as does integrating the various forms of technology within a system. To be able to offer the right solution for almost any industry and any corner of the globe, you need to have a global presence, application knowledge, and an extensive product portfolio. Ideally, all of this will flow into full end-to-end solutions; solutions that can be standardized where possible, duplicated, and used in other areas. Track and trace systems like the Lector65x

System therefore have a lot to offer. The type of camera (fixed focus or dynamic focus), the number of cameras, and their alignment are customized to the application in question – from reading the top of parcels or tires (the Tire Lector Array) all the way through to 5-sided reading for parcels or flight baggage (ALIS Vision). By integrating the networking concept from SICK into the MSC800 network controller, the Lector65x system can intelligently be combined with other technology, such as ICR8xx line-scanning cameras, volume measurement systems, laser-based code readers, or weighing scales. (tm)

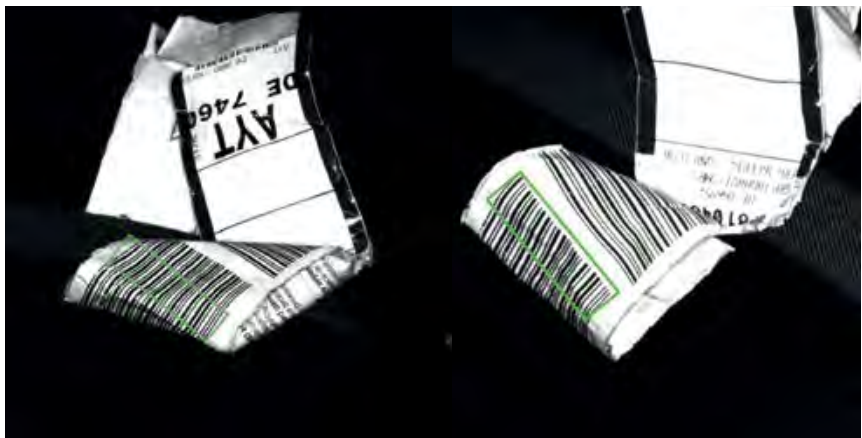

Thanks to the integration of the Lector65x, the system can read even the most crumpled labels.

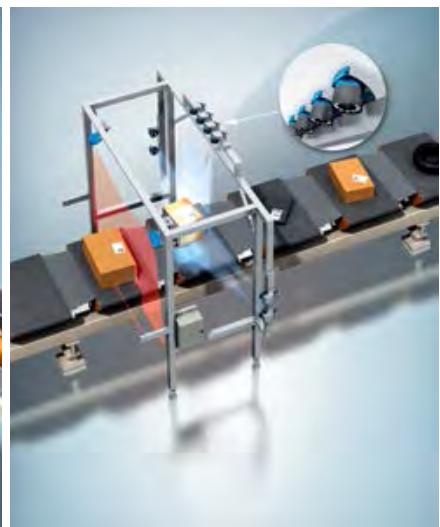

One system solution, lots of applications: reliable identification and traceability for tires, flight baggage, or parcels.



3D VISION TECHNOLOGY FOR DRIVER ASSISTANCE AT PORTS

KEEPING AN EYE ON EVERYTHING AROUND THE REACH STACKER

No matter what the weather, you will find countless reach stackers in use at every port. The rugged Visionary-B CV 3D vision sensor with snapshot technology by SICK supports reach stacker operators with their frequent maneuvering and reversing operations. To help with this, the sensor detects relevant objects in the vehicle's environment and generates live images that appear on the monitor. At the same time, the sensor uses visual and acoustic signals to warn the driver of possible collisions in critical driving situations. A plug and play solution, the Visionary-B CV is a breeze to configure and operate, and is ready for use in a matter of moments.

>> A reach stacker operator needs to deal with many different tasks. Although this includes driving the reach stacker, that is not the operator's most critical task. Instead, the operator needs to be able to focus on container turnover. What's more, unlike normal cars, reach stackers are not just used for brief periods, but they maneuver backwards for several hours at a time. This is precisely where the Visionary-B CV can help thanks to the use of 3D technology. The technology

means that the operator does not need to constantly concentrate on the monitor as is the case for conventional passive camera systems. The Visionary-B CV lets the operator focus on the key tasks while still maintaining awareness of critical situations whenever they occur.

Snapshot technology using the two-eye principle

The Visionary-B CV records objects around the vehicle with two images from slightly

different perspectives. These two slightly different images are used to calculate information about the distance, which represents the third dimension. The principle of operation is similar to the way humans perceive space. Using this two-eye principle, the sensor head captures raw 3D data and transmits it to the evaluation unit which is programmed to analyze the vehicle's environment and warn the operator only in the event of critical situations. The built-in data evaluation unit



from SICK enables reliable detection of two classes of outdoor objects. Object class 1 detects larger vehicles and other relevant obstacles, such as electrical cabinets, within the monitoring zone. Object class 2 checks the vehicle width against the detection zone. This configuration is suitable for areas like narrow passages because it means that no unnecessary and distracting signals are emitted. The sensor works as a stand-alone solution and also includes an integrated recording function, which can be used for continuous data recording.

Making the blind spot visible again

The typical reach stacker rear end is 2 m tall and 3 m wide. This size creates blind spots directly behind the vehicle that need to be made visible to the operator. Several kits are available in version A, B, or C. Kit A for the Visionary-B CV fulfills this task with utmost efficiency. The kit consists of a sensor head, an evaluation unit, a monitor, and corresponding mounting tools. Anyone looking to equip a wider vehicle or anyone who finds that

the vehicle's shape means that one sensor head is not enough can use kit C. Kit C is made up of two sensor heads and evaluation units, which apply a master-slave principle to emit the merged signal via a discrete output to one or, if necessary, two monitors. Kit B is used if you wish to make the areas both in front of and behind the vehicle visible. Kit B is made up of two sensor heads, an evaluation unit, a monitor, and a switch box that switches between the necessary sensor heads. Variable configurations are available for the detection zones so that the driver assistance system triggers a warning only in truly critical situations. Matching the vehicle width to the detection zone ensures there are not any superfluous signals, such as when driving through narrow passages. Visionary-B CV kits from SICK are an indispensable aid in cases where a reach stacker operator is looking to concentrate more on his main job of turning over containers instead of just on driving. (ro)



Monitor with live images of the vehicle environment.



The Visionary-B CV is based on the stereoscopic principle, which is similar to the way that humans perceive space.

LOCATING AND TESTING

JAM JARS: VACUUMS A NECESSITY – LID INTEGRITY INSPECTION WITH THE TRISPECTOR1000 3D VISION SENSOR

When it comes to metal closures in packaging, nothing can be left to chance: In products such as jam jars, the consumer goods industry requires seals to be tight and jars to be hermetically sealed. Anyone who makes their own jam will know that a small indentation in the lid is the key to creating the perfect vacuum. However, this small feature is difficult to identify by eye in industrial production contexts involving high numbers of parts and high speeds.



>> Fynbo Foods A/S, a leading Danish manufacturer of jams, preserves, and fruit spreads, uses the SICK TriSpector1000 3D vision sensor on its Vraa production lines to check the integrity of seals. As a manufacturer for the organic and fair markets, Fynbo Foods stands for healthy, sustainable products that conform to high standards of quality. That was why the company needed to find a reliable inspection solution

for quality inspections on its sealed jars. Once the jam has been successfully pasteurized, the lid has a small indentation as a result of the vacuum created in the process. If pasteurization goes wrong, on the other hand, the lid will have a slight bulge. Only tight lids can prevent pressure compensation from taking place. The TriSpector's role is to identify any minor deviations in the lid surface.

The TriSpector1000 inspects two jars each second; faulty goods are then ejected from the process.

"We tested out a range of other solutions. The TriSpector is the only one that is able to do the job perfectly. What's more, it's easy to use – when I installed additional devices, I was able to simply copy across the configuration," explains Jesper Juul Nielsen, an electrician at Fynbo Foods.

Plane Tool

The TriSpector1000 is a configurable stand-alone sensor for cost-effective 3D inspections. It can stand up to any challenge, whatever the product's shape, color, or alignment – meaning that contents, completeness, and emptiness can now be inspected in every dimension. It is ideally suited for use in quality control systems in the consumer goods and packaging industry. Thanks to its intuitive parameterization software, the TriSpector1000 guarantees easy commissioning and configuration. What's more, the device can easily reuse stored settings such as those concerning the

field of view, thus allowing it to be replaced quickly.

With the TriSpector1000, even complex inspections can be carried out quickly, easily, and with a high degree of availability. Three different variants for a variety of work areas – 56 mm to 116 mm, 141 mm to 514 mm, and 321 mm to 1,121 mm – ensure optimal execution of tasks and integration of the sensor into the machine environment. The single-housing concept ensures geometric stability and precision in measuring scenarios. 3D image detection of moving



The TriSpector1000 is available with three different fields of view, for a wide range of applications.

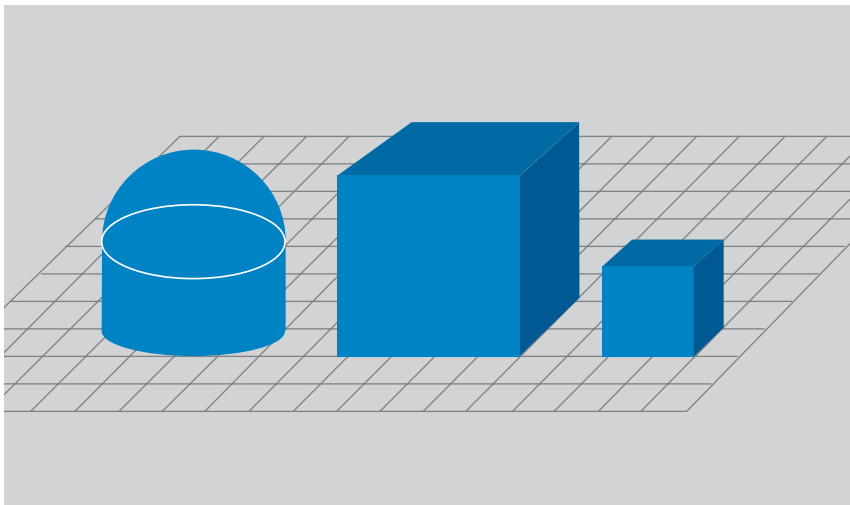

The TriSpector1000 Plane Tool automatically scans the angle of surfaces such as lids or jar seals, and measures whether they are horizontal or crooked.

objects by means of laser triangulation is not affected by object properties, background influences, or factors related to illumination and ambient light. At the same time, the device provides as many as 2,000 3D profiles per second – with high-resolution measurement results that the vision sensor converts into mm values for immediate further processing. This allows mechanical engineers and integrators to duplicate identical inspection tasks quickly and easily, and enables the user to replace a device without any delay through the use of stored data and configurations, should this be required. The data output via digital outputs and the Gigabit Ethernet interface enable fast responses, wherever necessary, by means of processing and machine control.

Container checking with the TriSpector1000 3D vision sensor

Whether they are soft drinks, wine, liqueurs, cooking oil, or liquid seasonings, most goods that are packed in bottles are then grouped into containers. Incomplete containers are considered faulty and therefore unacceptable.

In these cases, it may be that the boxes are missing some of their contents, or that individual bottles have fallen over. Often there are also shiny finishes on bottle lids to contend with, as well as lids with different colors or a natural aluminum color. With all these visual variations possible, inspections can place extreme demands on 2D camera inspections. That is why 3D inspection is the more suitable solution – and a reliable method of preventing complaints.

Detecting and counting objects in a group

The TriSpector1000 performs a “free-running scan” that enables it to detect and count the necks of bottles in three dimensions. Any reflective areas of the



Quality control in the consumer goods and packaging industry is the ideal application.

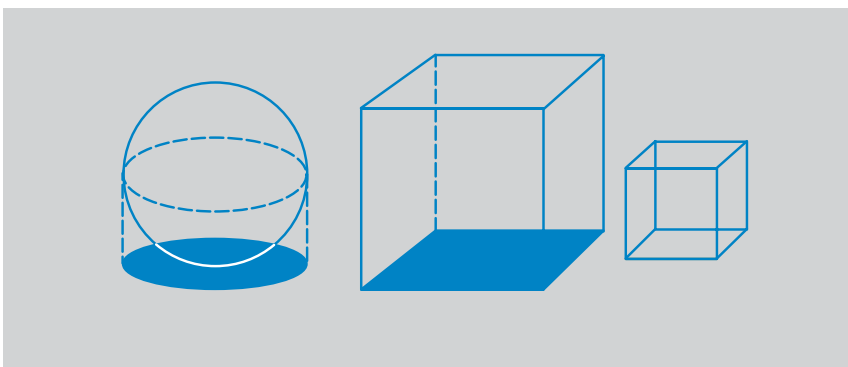

With the Blob Locator Tool, the TriSpector100 locates objects within a user-specific size range, even if the objects vary in shape.

lids are adapted to by tilting the camera or changing the settings. If faulty containers are identified, the sensor activates an ejector that enables the operator to correct the contents of the box.

In the packaging industry, it is crucial that packaging is delivered with its contents complete. With the Blob Locator Tool, the TriSpector1000 locates objects within a user-defined size range, even if they have different shapes. This makes it possible to check automatically whether a box contains the correct number of chocolates, for example. (as)

HIGH IMAGE QUALITY – THE KEY TO VISION TASK SOLUTIONS

LIPTON: INSPECTOR 2D VISION SENSOR CHECKS CORRECT POSITIONING OF TEA BAG LABELS

After water, tea is the world's most consumed beverage. More than three billion cups are drunk each year in countries across the globe – the equivalent of around 450 cups per person in a year. As a beverage, tea is unique in that it is an everyday part of life for the whole gamut of global cultures.

>> With representation in more than 150 countries, Lipton is the world's leading tea brand. Each year, people across the globe consume more than 100 billion cups of the company's tea. Lipton's second-largest plant is located in Dubai, a strategically advantageous location between tea cultivation areas in Asia and tea consumer markets.

Here, Unilever deploys Inspector I40 2D vision sensors during the packaging process as a means of checking whether labels are present on tea bags, and what position they are in.

Tea bags have an ingenious design with pores that let hot water in and flavor out. The strings and labels attached to some of them make it easier to remove the tea bag from the hot beverage or the cup. Printing information about the company and the bag's contents on the labels also provides an advertising platform.

In cases where tea bags are placed in one or more rows in boxes without any other packaging, Unilever attaches great importance to checking that the labels are positioned directly next to their associated bags – and not anywhere else – before the lid is closed. Each thread, with label attached, should be wound around its bag; otherwise, there is the risk of threads becoming tangled and torn away from

the bags when the boxes are closed and move to the next stages in the packaging line. Once filled, most boxes of tea are wrapped in a transparent film with a pull strip that allows it to be removed – but if a bag label is in the way, this process also has the potential to go wrong. In addition to being aware of production risks, household-name brands know that presenting their products perfectly is a must.

Outputting user-defined good-or-bad results

Equipped with a wide-angle lens for a large field of view in close-range installations, and a blue color filter to ensure higher contrast, the Inspector I40 is able to differentiate reliably between the reference image of a perfectly filled box of tea bags and images showing labels out of place. This intelligent solution removes the need for an additional PC to evaluate images. The sensor is connected directly to the control or a pusher via its digital outputs.

In the Lipton plant in Dubai, two Inspector I40 devices are responsible for inspecting the boxes of tea bags, with one working at each of the boxes' long sides. The simple configuration in SOPAS, including an emulator for offline configuration, makes it easier to transfer settings between one device and the other.

Intelligent image processing solution in an easy-to-use sensor package

The Inspector I40 combines a high-resolution image sensor with an additional speed boost, improving image quality. Its powerful testing toolkit provides straightforward solutions that are easy to configure. One of the most efficient object identification algorithms is able to track the part or detail that is to be inspected, regardless of its position, rotation, or size in the image field. This enables reliable inspections without the need to

know the exact location of the object, thus accommodating any deviations in the product position's repeatability.

Quality control challenges

The Inspector vision sensor for image processing applications represents an intelligent solution in a single device, and can be relied upon whatever the task: quality and completeness verification, part position detection, or measuring applications.

Fit for industrial use

The rugged IP67 metal housing is adapted for industrial use and, thanks to its intelligent image processing, the Inspector is perfect for applications involving high speeds. The Inspector I-series versions are built to stand up to the chal-



The Inspector I-series can conquer demanding inspection tasks. Increased contrast thanks to the use of a blue filter.



Tea boxes with poorly positioned labels are ejected.

lenges that demanding inspection tasks present, with an integrated toolkit that verifies quality and completeness. The Inspector sensors deliver reliable performance even in changing ambient light conditions, and slight distance variations do not affect them. Its flexible, interchangeable lens makes it easy to optimize image quality. And with front screens that can be swapped out, the I-series represents the perfect single-component solution for a whole host of applications. (as)

SOLUTION FOR READING DATA MATRIX CODES ON CURVED STORAGE CONTAINERS

MAKING SURE THE WORLD GOES ROUND: SEAMLESS TRACEABILITY AND COUNTERFEIT PROTECTION FOR PHARMACEUTICALS

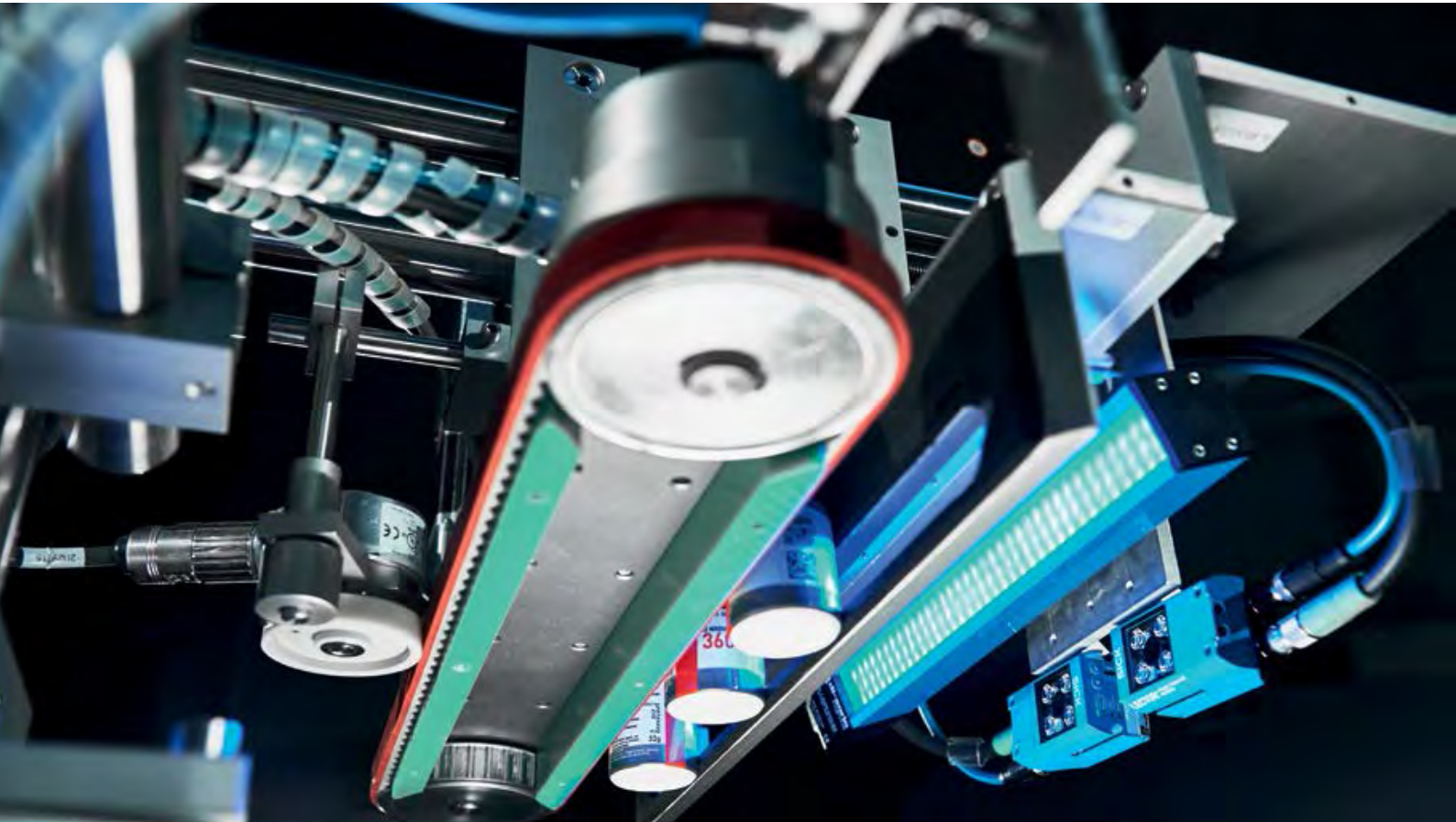

Counterfeit pharmaceuticals cause major financial losses, can pose health risks, and undermine patients' trust. In light of this, the pharmaceuticals industry has committed itself to implementing the EU directive 2011/62/EU of the European Parliament and Council dated June 8, 2011, by 2018. The falsified medicines directive, as it is known, aims to guarantee traceability and transparency in the supply chain. The pharmaceuticals industry is therefore on the lookout for solutions that will ensure counterfeit protection for pharmaceutical products. The company i-mation GmbH, a manufacturer of industrial image processing systems based in Rottweil, Germany, can now offer them a solution that simplifies the read process for curved storage containers. The system is based on the strong performance of the Lector620 High Speed image-based code reader by SICK.

>> The pharmaceuticals industry uses Data Matrix codes for the unique identification and serialization of products and to guarantee their traceability and counterfeit protection. Data Matrix codes encrypt a pharmaceutical product's part numbers, serial and batch numbers, quantity and weight data, and the expiry

date in just a single code. Further benefits of Data Matrix codes stem from their small, space-saving symbology and their high capacity for data. Furthermore, they are very reliable during the printing and reading process, making them safe to read. Data Matrix codes are easy to attach and read if they are used on car-

tons, boxes, and angled packaging. "For round packaging, like bottles, tubes, or vials, this is not the case," explains Ralf Sinnerbrink, the head of customer projects at i-mation: "Depending on which way the product rotates, the code on curved containers is often impossible to identify."

Quality checks and reading codes on curved containers

With the ID Module 360, i-mation has developed a simple and safe system for reading all conventional 1D and 2D codes – including Data Matrix codes – on curved containers. To achieve this, up to two image-based Lector620 High Speed code readers by SICK are integrated into the system and positioned above a conveyor belt. The code readers can be adjusted in accordance with the product’s individual diameter. “Depending on the code or cell size of the Data Matrix code, you need just one image-based code reader for products with a diameter up to 50 mm and two readers for products up to 100 mm,” explains Sinnerbrink. “With the old system, existing products on the market had to be isolated so that the codes were not covered during the reading process. And the cameras had to be mechanically adjusted to the diameter of each product to make sure they generated sharp images. All of this is now redundant thanks to our ID Module 360. The new system is also significantly narrower – thanks to the Lector620 High

Speed. Its compact design even allows it to be mounted in locations with very little space.” At the infeed area for the tape, a WTB4-3 miniature photoelectric sensor by SICK registers the products so that the code can be clearly assigned to the product. This is the only way to guarantee accurate traceability during the wrapping process. During wrapping, the product is rotated by at least 360°, which enables the camera to achieve optimum alignment. The Lector620 High Speed quickly and reliably detects products that have been coded incorrectly or have no code, which makes it particularly well suited to high-speed applications. This helps to achieve high throughputs while also dealing with high quantities in product control at the same time. Signals easily identify products with the wrong code or no code so that they can be ejected from production.

is because it reads all conventional 1D codes (bar and stacked codes) and 2D codes (Data Matrix codes, QR codes), as well as plain text (OCR), which is often used for the serialization of pharmaceuticals. Packaging is marked with a unique combination of letters and/or numbers for this purpose. The Lector62x can detect codes at intervals of between 30 mm and 300 mm. As a result, it offers the flexibility needed to identify products of various sizes. “With its built-in red and blue illumination, the Lector62x can also light up its reading field perfectly at any time, regardless of the contrast” explains Patrick Braun, Product Manager at SICK. “This means that it can still read codes of the poorest quality,” continues Braun. Furthermore, the code reader provides ultimate process security and availability, and can also be operated without any specialist expertise thanks to the intelligent decoding algorithms that evaluate the quality of the code read result.

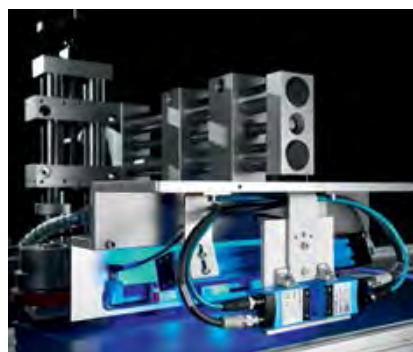

The Lector620 High Speed quickly and reliably detects products that have been coded incorrectly or have no code.



The Lector62x: an all-rounder by SICK

The Lector62x image-based code reader is an intelligent SICK 4Dpro sensor for automatic, stationary decoding of codes on mobile or stationary objects. The code reader is tailor-made to suit industry requirements and is also the ideal solution for the pharmaceuticals business. This

Well connected thanks to 4Dpro

With its wide array of connection options, the Lector62x can be seamlessly connected to new or existing systems – thanks to the uniform user interface, the plant is ready for use in just the blink of an eye: 4Dpro also allows the device to be integrated into countless industrial networks (Ethernet, PROFINET, PROFIBUS, and CAN). The Lector62x uses its host interface to send the read data to a higher-level computer for further processing. (fd/ro)

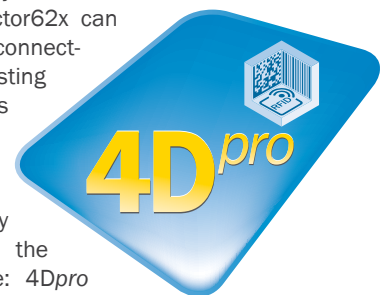



RANGER 3D VISION CAMERA UNLOCKS A WHOLE NEW SET OF OPPORTUNITIES FOR APPLICATIONS

MAXIMUM PERFORMANCE THANKS TO ADDITIONAL HEIGHT MONITORING

scanware electronic GmbH in Bickenbach, Germany, develops and manufactures inspection systems for the 3D quality control of pharmaceutical products during the packing process. Nowadays, 2D cameras are no longer up to the inspection tasks set by packaging machine manufacturers and pharmaceutical companies. That's why, for ten years now, scanware has relied on the high-resolution, versatile Ranger 3D vision camera from SICK when it comes to developing custom solutions. The extremely high speed during the transmission of the line profiles can even keep up with especially fast-paced packaging machines – meaning that quality doesn't fall by the wayside.

>> Since as early as 2006, responding to a customer request, scanware had been searching for a solution that could ensure that blister packages were filled correctly. "It was a matter of ensuring the quality of sealed aluminum blisters. Guaranteeing the quality of the product meant detecting the smallest of deformations in the aluminum that occur during the transport process in the machine," said Harald Mätzig, Managing Director of scanware, looking back. Possible solutions to this task were trialed using grayscale and color cam-

eras in combination with a wide variety of illumination techniques – but to no avail. "We were looking for a product to be used on a very fast packaging machine. It had to have a high processing speed as well as a high resolution," said Mätzig. "It was at the 'Vision 2006' trade fair that we discovered SICK's Ranger C50 streaming camera that we then tested. Our trials were a success and in 2007 we installed the Ranger on a packaging machine that was ultimately used in production for quality control purposes."

3D monitoring for tablets, capsules, and small power quantities

From 2008, the scanware team began to further develop the existing LYNX-SPECTRA CL/HR image processing systems on the basis of color product inspection. The result was the LYNX-SPECTRA 3D system: a high-resolution, laser-based image processing system for the 3D monitoring of foil, tablet, and capsule geometry for undesirable deformations of any kind, such as dents, bulges, or spalling. Dominik Hüfner, System Developer at scanware, explains: "The scanware 3D

system consists of a color part and a 3D part with a Ranger C50 streaming camera from SICK to check products in terms of color, shape, and volume.” The standard Ranger configuration was an X/Y/Z resolution of ~0.1 mm/pixel at a conveyor speed of up to 1.5 m/s. “This camera allows us to generate very high-quality 3D data at a very high speed,” said Hübner. “It opens up a whole new set of possibilities for monitoring product characteristics that are not easy to detect with a 2D camera. Firstly, additional height monitoring ensures the reliable detection of defects in products and packaging. For example, if tablets are standing up on end, they may break through the sealing foil during the sealing process, meaning that the blister is not completely sealed. Or if tablets have broken apart in the middle and only half is in the blister. Now Ranger has made it possible to reliably detect defects

like this in terms of height and volume. As a result of this, we are also able to remove defective products and packaging from production.” The scanware system is even suitable for monitoring a dosed volume of small powder quantities in aluminum blister strips.

Integration and adaptation to custom applications

Expanding the pre-existing LYNX-SPECTRA CL/HR color systems with the Ranger streaming camera from SICK was not done without mechanical and electrical challenges. For example, the results of the camera had to be linked to the color system and transmitted to the machine. What’s more, the Ranger camera had to be integrated into existing and new packaging machines from a variety of manufacturers. As a result, the camera was completely implemented under the QNX real-time operating system.

The 3D image is generated using a laser triangulation process. The image-recording geometry for the laser triangulation process was built into a scanware illumination unit, with the laser units being able to be reduced in size thanks to mirror deflection. Using the Ranger C50 requires a frame grabber and a multi-camera switcher board that supports line-oriented image transmission. As all analysis algorithms were developed in-house, a higher degree of flexibility could be achieved when adapting the system to custom applications, while still ensuring maximum performance.

Easy operability, maximum safety, and a wide range of applications

The scanware LYNX-SPECTRA 3D system featuring the SICK Ranger C50 streaming camera is easy to operate thanks to its user interface that corresponds to the standardized menu structure of all

scanware systems. The scanware image processing library has been expanded with 3D analysis algorithms. In order to provide a better understanding of the analysis results, the system is equipped with 3D visualization. The system is certified to laser class 1, meaning that it offers maximum safety for the user. The Ranger camera features the unique MultiScan function that facilitates the simultaneous measurement of a multitude of other object characteristics, such as contrast, gloss, and laser scattering. As a result, Ranger boasts better detection capabilities for low-contrast objects, such as gray on aluminum. The provision of all information from just one single Ranger camera enables safe decisions and cost-efficient solutions. Harald Mätzig states: “Our experiences with the Ranger camera from a wide range of requirements with regard to speed and resolution mean that we can now offer a broad spectrum of customer applications.”

Building on the many years of positive experiences that scanware has had with the Ranger C50 streaming camera from SICK, the new LYNX-SPECTRA 3D color system type – which makes pixel-precise combination of 3D and color data in a single system possible – is set to hit the market in the near future. This system uses the ColorRanger E50 3D camera from SICK. “ColorRanger allows us to overlay 3D data and color data with pixel precision and therefore evaluate color and 3D in a single passage,” explains Dominik Hübner. In particular, reducing the size enables better integration on small machines and systems. “As we are able to significantly reduce the size, we gain additional opportunities to make custom systems even more compact, as color and 3D can now be installed in a single housing.” (ro)



3D monitoring for tablets, capsules, and small quantities of powder.



INSPECTION OF MAGNESIUM BRICKS WITH
3D VISION TECHNOLOGY FROM SICK

QUALITY CONTROL WITHOUT DOWNTIME

Producers of building materials want to ensure that their products are of the highest quality possible, and in the production of special bricks for blast furnaces – which are particularly susceptible to surface damage – being able to carry out quality control during the production process is indispensable. A system has been developed in the Czech Republic, where bricks are scanned during transport on conveyor belts. As part of this scan, 3D vision sensors from SICK create 3D models of each individual brick. The 3D models can be used to determine the precise dimensions of the brick and the extent of its damage.



>> The system consists of an automated robot from ABB (a leading international company in energy and automation engineering), a control panel, a sensor for precise width measurement, and four IVC-3D vision sensors from SICK. These sensors feature an optical resolution of 0.2 mm, and are capable of performing in the unfavorable industrial conditions. The 3D vision sensors operate according to the principle of triangulation distance measurement. The line laser beam, which is integrated into the sensor housing, projects a light track on objects, allowing their profile to be determined. The IVC-3D sensors are able to use these profiles to create precise 3D images of the magnesium bricks, measuring them with high precision and detecting volume errors. This allows the quality of the bricks to be checked during the production process, meaning defective objects can be quickly discarded.

Connecting a network of communicating sensors

The IVC Studio software, which can be used to create bespoke measuring programs with more than 100 tools, was applied to program the IVC-3D vision sensors. The measuring program is saved in the flash memory of the IVC-3Ds, allowing them to continue to operate without being connected to a computer. In this system, the IVC-3Ds are mounted around specially designed conveyors, networked in a way that allows them to communicate with one another. In each system, one of the 3D vision sensors is designated as the control sensor, collecting information from subordinate sensors and transmitting the measurement results to the automated ABB IRB 6640 Foundry robot, which is responsible for the mechanical loading and unloading of bricks from the conveyor belts. At the same time, the 3D vision sensors communicate with the control panel. This control panel allows for the entry of the measurement parameters and, where necessary, data archiving for subsequent inspection. An OD Preci-

sion displacement measurement sensor from SICK, which boasts a measurement accuracy of 0.01 mm, additionally supports the whole system.

Simple operation with excellent process overview

Operation of the control system is simple: Initiating the robotic unit is as easy as pressing the START button. Transport carriages bring the bricks to the designated location, where they are unloaded on pallets. From here, the robot loads individual bricks onto the conveyor. After scanning, the 3D control system systematically assesses the properties of the bricks and transmits data on their quality to the robot. Finally, the bricks are stacked on one of four pallets. The control panel temporarily displays the measured values before permanently saving them, and a red warning light alerts the operator to any defective products. System parameters, such as individual tolerance thresholds, can be easily configured via the operating panel, allowing the system to be flexibly adjusted according to changing requirements. This wide range of adjustment possibilities means the system can ensure optimum quality for an enormous number of product types. (ro)

INLINE QUALITY CONTROL USING TURNKEY VISION SOLUTIONS

WHEN MACHINES CAN MONITOR THEMSELVES

Consistent quality, very few rejects, reliable part and batch tracking, added transparency: The use of vision sensors for quality control directly in the production process offers a number of benefits. Depending on the task at hand, you need to have the right vision solutions, which allow for quick and efficient integration into your machine. With over 30 years of experience in vision technology and the relevant knowledge of applications, SICK has a wide range of suitable solutions.

>> The later an error is detected in the production process, the more costs it incurs and scrap material it causes. In light of this, it is therefore essential to detect errors as early as possible. At the same time, the evaluation of quality attributes enables users to identify any measures needed in production facilities or for production material. Vision sensors are ideal for dealing with these issues. Their spectrum stretches from 2D monitoring for simple production features and operating material attributes to high-end tests using 3D vision systems. Rejects and costs are cut as a result. Yet another benefit: The individual images from the vision sensors are stored and kept available for a later date – perfectly in keeping with the principles of Industry 4.0 and added transparency. Vision solutions used to be used primarily for monitoring production material at end customers. However, an increasing number of machine manufacturers and OEMs are joining the trend of incorporating the issue of quality control into their machines and plants – another step towards creating complete solutions for the end customers. (tm)

DETECTING ERRORS AT THEIR SOURCE – THE BENEFITS OF INLINE QUALITY CONTROL:

FORMING MACHINE TOOLS, PUNCH PRESS



Vision sensors like the Inspector conduct ongoing checks of the punched contours or holes directly in the process. Irregularities or errors in the punching process are therefore detected immediately and with full reliability. An added bonus even for the flexible production of small batch sizes: The operator can access pre-defined test parameters when changing a batch or use functions to modify the parameters himself – so you don't need to be a vision expert. The results of the thorough check are evaluated in the vision sensor itself and passed on accordingly.

Automatic crack tests in car panels at BMW:
www.sickinsight-online.com/bmw

CUTTING MACHINE TOOLS, POWERTRAIN



Are all of the holes and recesses in place and correct? To conduct a full quality check after processing a motor block, an Inspector vision sensor not only checks that all contours and holes are in place, it also makes sure they are the right shape. Any parts that have not been processed correctly can be rejected before further processing. The production process can then be stopped in good time, for example, if you need to replace any damaged tools. Furthermore, the sensor uses taught-in features to identify the individual parts. This information is sent to the control unit for the next machine in the line so that the production process can be modified if necessary.

Find out more:
www.sick.com/de/en/industries/machine-tools/

INJECTION MOLDING MACHINES: POSITION MONITORING AND QUALITY CONTROL



The plastic and rubber industry requires a high level of efficiency and economy with a consistent level of quality. The use of vision solutions offers a number of benefits: For instance, a vision sensor can check whether an insert has been placed correctly into the injection molding machine's mold. Having the component in the right position prevents damage to the tool and, as a result, reduces machine downtime, while at the same time improving the quality of the part in question. In the production of injection-molded plastic parts, the quality of the final product also depends on a number of factors, such as temperature fluctuations, fluctuating quality in the plastic granules, etc. Inline quality control using vision sensors can also offer advantages in this case: Errors such as over- or underfilling are detected reliably so that faulty parts can be safely separated and ejected.

Quality control using vision sensors in Arburg's injection molding machines:
www.sickinsight-online.com/arburg

MONITORING WELDING CAPS AND LASER NOZZLES

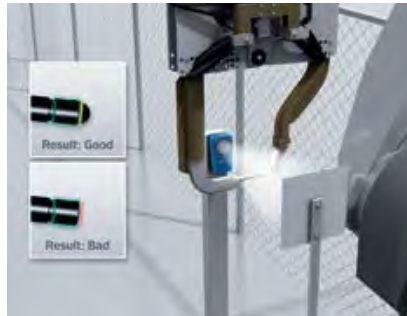

When welding or cutting metal panels, the quality of the welding caps on the welding gun or laser cutting device has to be monitored on an ongoing basis. Welding caps wear off as the processing time increases, requiring them to be replaced. An Inspector 2D vision sensor checks defined parameters, such as shape and diameter, and detects irregularities that cannot be tolerated. The operator can then replace the welding caps in good time so that product quality remains consistent.

Find out more:
www.sick.com/automobil

QUALITY CONTROL IN THE PROCESSING OF SAWN TIMBER

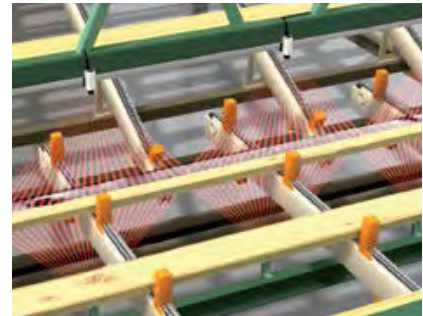

Powerful 3D vision solutions make a valuable contribution to the quality of the final product. For example, the Ranger E 3D vision sensor can generate an exact image of the surface of the board when processing sawn timber. As a result, potential errors and undesirable irregularities on the board, such as cracks, gaps, spots, rot, resin, or knots, can be clearly detected. This inline quality check using 3D vision solutions is equally well suited for the production of flat glass and plastics.

Find out more:
www.sick.com/holz



FLEXIBLE DESIGN AND HIGH THROUGHPUT IN A SINGLE SYSTEM

THE MARRIAGE OF TRANSPONDERS

An increasing number of digital solutions are also being used in the fashion and clothing industries. The opportunities range from labeling products and presentations in stores all the way through to interaction with the online shop.

>> As announced as part of its current reorientation strategy (known as "FIT-4GROWTH"), the GERRY WEBER group will be placing more focus on the issue of digitalization in future and making the most of the potential in omni-channel retail.

The company has already established an important basis for this process by investing in a new logistics center and modifying its logistics processes. The new logistics center in Ravenna Park in Halle, Westphalia, has been in the ramp-up phase since December 2015. This center is where GERRY WEBER will control all of its own logistics processes in future.

With the launch of the new logistics center, the previously decentralized logistics structures will be optimized and bundled

at a single site. Currently being stored in separate warehouses and at the company's logistics partners during the transition period, hanging garments and flat-packed goods will be brought together in the new logistics center in a step-by-step process.

The accelerated value chain for the world of fast fashion and the dynamic changes resulting from increased digitalization require high-quality data and seamless data transparency throughout the entire value chain. GERRY WEBER



first launched a project for optimizing its entire international value chain back in 2009. As part of this project, RFID was employed for optimizing logistics workflows and retail processes, as well as being used as a new form of goods security. During this development process, the company came up with another innovative idea: The “normal” care label was enhanced to create a textile RFID label that combined the security function, the manufacturer’s care notes, and an electronic product code. This code is now even due to “get married” in the new logistics center.

The right products in the right place

GERRY WEBER uses RFID systems by SICK for fully automated picking and identifying items of clothing. The RFID

gate system RF-GOH for hanging garments and the RFID tunnel system RFMS Pro were designed in conjunction with the conveyor system manufacturer and integrated into the new GERRY WEBER logistics center. Further manual picking stations are also equipped with RFID technology by SICK.

Hangings products: marrying the transponders in the adapter link-in station

Sensitive clothing that you would normally hang up at home is stored on hangers and picked from there. This helps to avoid a possible drop in quality while at the same time ensuring that the customers receive a ready-to-wear piece of clothing when they buy it in store or get it delivered straight to their door.

To achieve fully-automated returns processing and order picking for hanging products that keeps order throughput times as short as possible and picking accuracy as high as possible, the new GERRY WEBER logistics center is equipped with two solutions that work well together: one UHF transponder on the care label in the item of clothing and one HF transponder in the roller adapter, which is used to hang the hanger up with the piece of clothing.

“Every item is fitted with an RFID tag at the goods entry point. The care label and RFID tag are not always stitched into the same place in every item of clothing. In light of this, a length of around 1.80 m has to be scanned in order to evaluate the first source. This takes place



Hanging garments on their way to getting married.

using the SICK gate,” explains Jürgen Dietsch, the Director Logistics Systems at GERRY WEBER International AG. “The other source is a small adapter which runs along the top in the roller adapter with a unique identification number. The challenge here is to allocate the transponder in the clothing to the HF transponder in the adapter so that the marriage can take place. We can now read this data and merge it together – consolidating HF (high frequency) and UHF (ultra high frequency). By consolidating information about the item of clothing with the ID number, the process can then be automated and generally improved across the board. Otherwise, we would have to install one of these

tunnel gates at every point where a decision has to be made. This then comes down to costs and space.”

The RF-GOH gate track and trace system

The RF-GOH system was developed specifically for RFID identification on hanging conveyor systems. The intelligent allocation algorithm allows several RFID tags to be read at the same time and also calculates the position of each RFID tag. This creates a unique link between the RFID tag and the hanging product – even for objects that are close together on the conveying line. Furthermore, the system detects and filters the static transponders in the surrounding area.

Based on SICK’s 4Dpro concept, bar code scanners and read devices can also be integrated into the system. For example, this allows the information in the UHF transponder in the item of clothing to be linked to the information in the HF transponder on the hanger. The same is true of merging the UHF data with the bar code data.

The modular MSC800 system controller forms the heart of the system. The hardware built into the controller and its integrated allocation algorithm generates a particularly high level of reliability. The MSC800 makes any relevant data from all of the integrated sensors available to the control system.

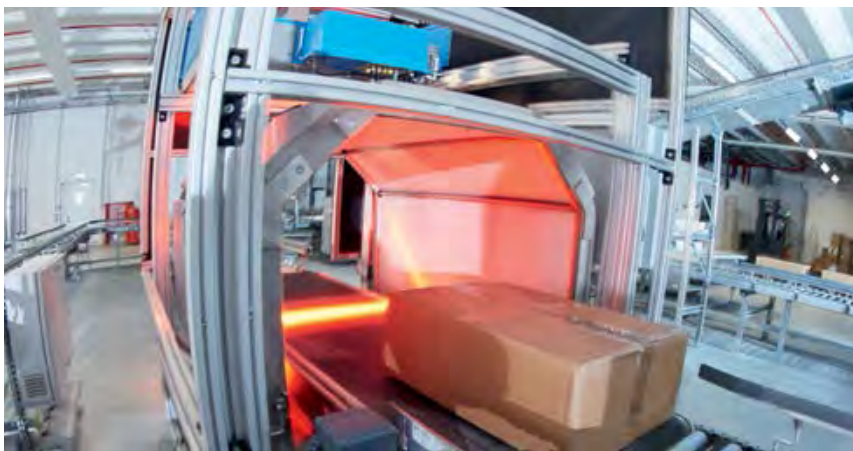

Folded items: All packaged clothing in shipping boxes are recorded in the tunnel gate.

The tunnel: The RFMS Pro track and trace system can even read hand-written notes

Items such as sweaters, shirts, or accessories are folded up for delivery. Any boxes full of folded items are tracked completely using the RFMS Pro track and trace system by SICK.

Because the transponders can be read reliably in the tunnel gate, any items packed tightly inside a shipping carton can be recorded.

With the RFMS Pro track and trace system, SICK combines tried-and-tested components and sensors used in a wide array of other solutions to form



Hanger rolling adapters with HF transponders.

an innovative end-to-end solution: The 4Dpro from SICK integrates the RFMS Pro easily into any application – even in combination with other technologies for automatic identification (a laser scanner or camera, for example). In addition, a solution to measure the volume can be integrated to output the dimensions of the particular object. The advantage: All required data are output via one unit and one interface.

The outstanding image quality of the built-in image-based ICR89x code reader also makes it suitable for use in OCR and video coding applications. “Besides RFID read/write devices, the tunnel is also equipped with an OCR camera for reading plain text on labels, such as handwritten information regarding quantity or other item attributes in the event of returns,” says Jürgen Dietsch, describing the requirements.

Pick-and-pack systems are used to send folded items to the stores or warehouses. GERRY WEBER uses UHF RFID RFU62x read/write devices from SICK for this purpose. Their well-defined, restricted read/write range is particularly well-suited for automatic identification over small object distances.

In this case, the scanned product is placed directly in the outgoing box. A pick-to-light indication makes sure the item is allocated to the right box. Finally,

one last scan verifies that the box contains what it is supposed to.



Pick-and-pack systems are used to send folded items to the stores and warehouses.

The new GERRY WEBER logistics center is currently in the ramp-up phase and capacity will be increased in a step-by-step process. At the moment, even more additional functions are being brought in to make the individual logistics processes even better. The logistics center is expected to start working at full capacity in 2016 and will turn over up to 30 million items per year. Capacity can also be increased to 37 million items a year if necessary.

The best technology depends on the task at hand

Increasing quality requirements and the desire for resource efficiency necessitate autonomous fault detection through comprehensive product and production

data. In the area of quality control, goods in the production process and value chain must be reliably and uniquely identified so that they can support efficient automated control.

In logistics automation, centralized data management and current data standards ensure transparency along the entire supply chain. They provide common access to important information concerning production-related questions (“what, when, where, and why”), and span location, national and company boundaries.

To provide efficient solutions for identification tasks, you really need more than just one type of technology. The track and trace systems by SICK are a flexible and intelligent all-in-one solution for goods receipt and goods issue in logistics. The systems consist of tried-and-tested solutions by SICK: read/write devices for RFID identification, a central controller with an integrated allocation algorithm, incremental encoders for determining the position and speed of the object and for measuring the distance between objects, photoelectric sensors for triggering the object, and optional laser scanners or cameras. (as)



More about the customer at:
www.gerryweber.com/en/



LECTOR CODE ANALYTICS DETECTS POOR PRINT QUALITY IN GOOD TIME

PREVENTING THE EFFECTS OF PROCESS ERRORS IN ADVANCE

In the consumer goods and food industry, the logistics sector, and the retail sector, reading codes on packaging and secondary packaging is an essential part of intralogistics and distribution processes. If a code is hard or even impossible to read, this will result in disruptions to the production process or downtime in sub-processes in the supply chain. To stop process errors causing poor print quality in the codes, SICK offers customers an intelligent solution: Thanks to the Lector Code Analytics function, process errors can be detected in good time so that their negative effects can be prevented in advance.

>> The configurable image-based code readers in the Lector® series provide the best possible read performance, allow for optimum throughput, and are equipped with the Code Analytics function. The Lector63x is a flexible, image-based code reader installed inside compact housing and features high image resolution and replaceable optics. This makes it particularly well suited to reading smaller codes from a great distance and with high production speeds. The Lector64x was designed for decoding 1D, 2D, and directly marked codes in real time. Thanks to its dynamic focus, the Lector65x offers a maximum degree of flexibility with regard to object height and transport speed. An image resolution of 2 to 4 megapixels gives it a large field of view, thereby ensuring maximum freedom for code positioning.

New Lector Code Analytics function for fine-tuning read results

Previously, the image-based code readers in the Lector® series could only distinguish between a good read result (Good Read) and no read results (No Read). This information could only indicate the actual read rate, e.g., 95%.



There was no way to determine the trigger for a No Read, meaning that the cause remained unclear. A poor read rate reduced throughput and the productivity of a plant. There was no way to determine whether the poor results stemmed from process-related factors or whether they were caused by faulty settings for the read technology, for example. With the help of the Lector Code Analytics software function (which is very easy to activate during configuration), the

Lector63x, Lector64x, and Lector65x image-based code readers can also use the images to generate additional information.

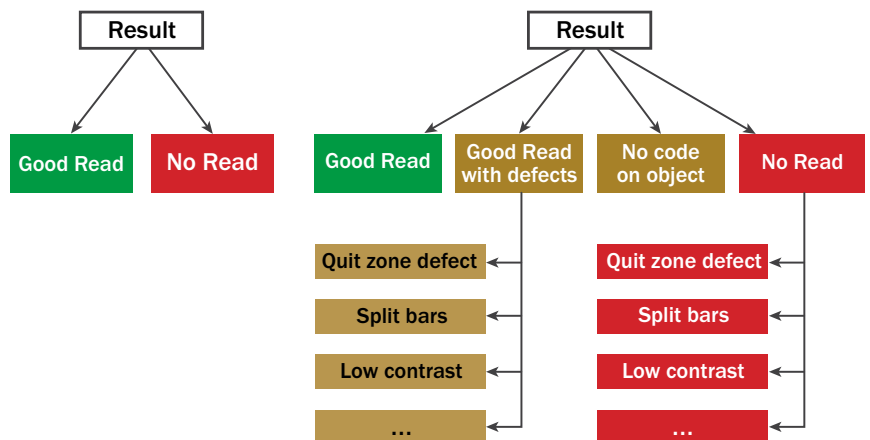
Products in the Lector® series can transmit this additional information to the plant control unit (PLC), which in turn can emit warnings at an early stage before the production line comes to a standstill. Furthermore, the information can be displayed via one of the read

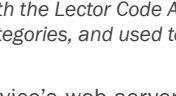

Better than good or nothing at all: Products from the Lector® series can now transmit additional information to the plant control unit (PLC).

TYPICAL PRINTING ERROR/CODE ERROR	RESULT OF CODE ANALYTICS	ERROR	CAUSES
	No code on the object	No code visible on the object	1. Object is the wrong way round or something has been stuck 2. Printer does not contain any more labels or has stopped printing
	Quiet zone is defective	Print head is printing the code too close to the edge of the label	Label is in the wrong position in the printer
	Bars are not complete	Bars are missing or do not run from end to end	Printer nozzle is blocked or defective
	Poor contrast	Low color intensity in the code	Printer ink is empty

With the Lector Code Analytics function, images of codes can be evaluated, assigned to error categories, and used to identify the reasons behind poor read results.

device's web servers. The user can, for example, receive notifications on the number of Good Reads, No Reads, and the number of objects without a code. This data can be used to determine effective read rates. With an effective read rate of say 90%, you can see precisely that, for example, 3% of the objects from the 10% of No Read codes did not have a code at all. Furthermore,

Lector Code Analytics can see when codes are in place but cannot be read and can even provide information on the possible causes.

SICK Sensor Intelligence. – Uncovering process errors and generating added value

With Lector Code Analytics, images of the codes can be emitted, stored, and

categorized very effectively. The images are therefore available to the user for process analysis purposes. Using the fault categories, the user receives criteria for identifying causes within the process that go beyond simple code reading. As a result, he can implement suitable measures in good time in order to prevent the print quality of the codes from deteriorating along with the throughput. With this intelligent solution from SICK, operators can reduce their workload, avoid downtime, and, above all, cut costs. This makes the entire process chain more stable, all the way down to the last identification point:

- Codes are used in every distribution center and sorting process
- Parcel services work with codes that are read by transit centers
- Food producers mark their products with codes that can be read at every stage in the supply chain
- The manufacturing industry uses codes in intralogistic processes and for sending out products

The added value is clear to see – after all, Lector Code Analytics means that poor quality or unreadable codes do not leave the premises in the first place. (ro)



RELIABLE INSTEAD OF RANDOM

DETECTION OF A DIVERSE RANGE OF OBJECTS

Quality means all of the properties in an object, system, or process being of a good standard. In the quality control facilities at an industrial manufacturing plant, production-based irregularities in products have to be recorded with information on their deviation from the target specifications.

Technical developments in micro-electronics now allow companies to use industrial image processing solutions with simple applicability. 3D applications can be used to tackle even the most complex inspections. However, quality checks can be carried out using simple detection features in a number of applications. The number one goal of object detection is normally to achieve the highest possible level of productivity for machines, plants, and processes. This makes detection quality and reliability a decisive factor for quality control and process quality. The suitability of the sensor solution depends on the

options available and can affect the plant's profitability.

Sensors from SICK are able to detect each and every object, be it transparent, perforated, small, uneven, shiny, or wrapped in film. In so doing, they assist seamless material flow in automation. Photoelectric sensors use various transmission sources to optimize optical performance and ensure universal object detection. The line-shaped light spot of a sensor detects irregularly shaped and perforated objects or shiny and uneven surfaces. A precise laser light point provides the basis for maximum accuracy

switching for small objects; a light band supports the detection of all objects varying in position or height regardless of location.

Intelligent optical sensors deliver more than just a switching signal – they provide a wide array of automation functions directly in the sensor and can be integrated into modern automation networks using the IO-Link global communication standard. Shifting existing control functions to the photoelectric sensors and decentralizing them in a network has a direct effect on machine productivity and process efficiency.

DeltaPac: for added efficiency and quality in the packaging industry

The DeltaPac MultiTask photoelectric sensor can count and identify products on the conveyor belt in a way that was not possible before. Without gaps. Without delays. DeltaPac accurately detects the transition between successive packaging items or workpieces. This ensures faster, smarter, more economical, and more reliable production. The product stream becomes more stable because packages no longer fall over, thus preventing collisions. Machine downtime, incorrect placement when grouping packaging, and loss of quality due to crashes are all reliably eliminated.

PS30: a pattern for success

The innovative PS30 pattern sensor uses contrast to determine positions. The trick? This allows it to detect two-dimensional patterns. To begin with, the system learns an image using distinctive reference areas with a good recognition factor. The line sensor then compares the target image with the actual image. As a result, the sensor knows exactly which contrast profile in the sequence comes next and which position it is in. This in turn makes special print marks redundant: The PS30 knows when a continuous web needs to be cut into the roll-fed labeling (without any unattractive design factors) or whether a package or tube is in the right position for interlocking. This saves on material and time. It mainly saves times because image determination using pre-defined reference areas reduces the amount of processing power required. The conveyor speed rises as the time needed to refit the ma-



The PS30 really plays to its strengths in presence monitoring applications and when identifying the position of labels, packaging material, or tubes.

chines falls – all thanks to the option to store several image profiles.

MLG-2: contours and transparency

MLG-2 automation light grids record everything. Even when it's practically invisible. Developed to detect small, speedy, and transparent objects with as much accuracy as possible, they are very well suited to quick and reliable detection. The sender/receiver system measures the length, width, and height of objects without being affected by colors and glossy surfaces. The MLG-2 functions in the same way as a line camera with up to 500 pixels. By evaluating the received energy, the camera can even detect changes in layers. As a result, the MLG-2 helps users to keep a constant eye on the product quality of napkins, textiles, paper, or even thin layers of plastic.

When in use, the MLG-2 is extremely rugged and even immune to dust, dirt, and ambient light. (mk/as)



Accurate and safe box volume measurement for various objects using the MLG-2.

INTELLIGENT MEASUREMENT TECHNOLOGY AT EVERY STEP OF THE PROCESS

MEASUREMENTS FOR ADDED QUALITY

A consistently high level of quality among parts and components can only be guaranteed if you regularly check results with measurements. These thorough checks are carried out using a wide array of methods, for example outside of the process by removing sample parts and conducting a mechanical check or by using measurement tools that are integrated directly into the production process. This is precisely the area where optical measuring sensors can show off their strengths.

>> Non-contact, precise, and speedy technology: The benefits of optical measuring sensors in contrast to mechanical measuring tools are clear for anyone to see. There is no need to touch the object to be measured so that sensitive materials are protected from distortion or damage. Optical measuring sensors can also be beneficial if the object's surface is difficult to access. Whether you opt for 1D or 2D laser triangulation, chromatic

confocal measurement processes, or 2D and 3D vision solutions: The high precision measurement of even the smallest object directly in the production process helps to guarantee added efficiency, while making sure quality remains consistently high at every stage of the process.

ULTIMATE PRECISION IN ANY APPLICATION

There is almost no end to the various fields of application for intelligent measurement technology - when it comes to finding the right solution, however, you need an extensive product portfolio and plenty of experience in using optical sensors.

Electronics: reliable measurement results in high demand

Displacement measurement sensors especially show their strength when it comes to dealing with fragile components: Because it has up to three sensor heads per evaluation unit, the OD Precision delivers measurement results with the maximum possible precision. As a result, you can monitor more than just the quality of the surface on individual electronic components, you can also make sure they are aligned correctly. And you do not even need to worry about compli-

cated calibration with the OD Precision.

Automotive and parts suppliers: precision on the production line

Whether you are installing the front screen or the dashboard: With displacement measurement sensors, grippers are precisely positioned using non-contact technology and a high level of reproducibility, and adapted to the components in question. The sensors' stand-alone concept means that you don't need any additional measured value work. This saves on space and cabling work, and includes speedy commissioning. The front screen or dashboard fits perfectly into position.

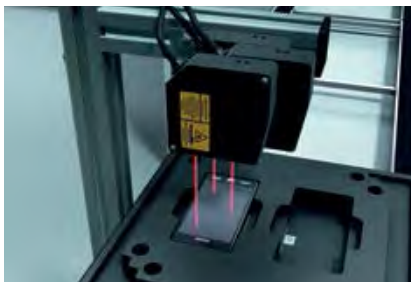

Monitoring the assembly process.



Precise positioning.

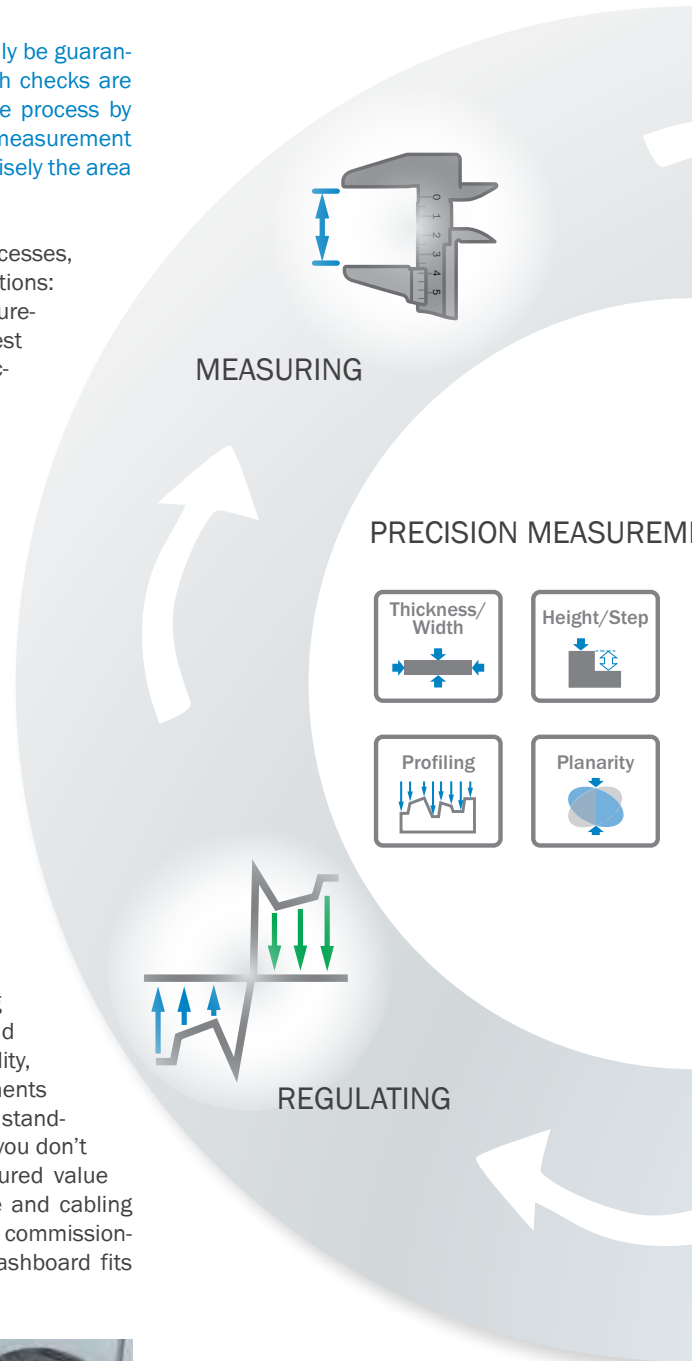

▶ 100% QUALITY: AT EVERY STEP OF THE PROCESS



MONITORING



EVENTS:

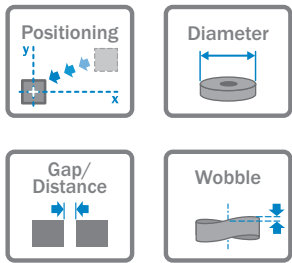

POSITIONING

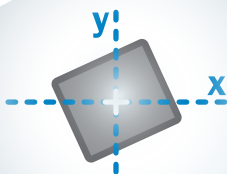

Machine tools: quality control from the word "go"

When dealing with sheets, heat and tension can often lead to unevenness or problems with the material. Displacement measurement sensors like the Profiler2 monitor the quality of the weld seam straight after the welding process – all within the process itself and at the earliest stage possible.

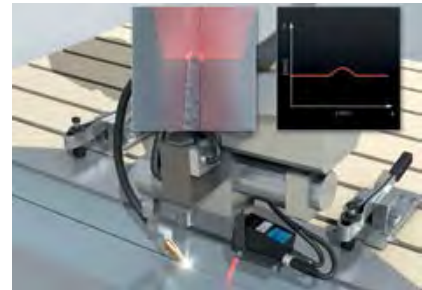

Measuring and monitoring.

2D OR 3D VISION AND DISPLACEMENT MEASUREMENT SENSORS

Always the right solution: Only providers with a strong knowledge of applications and an extensive technology portfolio can respond properly to various requirements. 1D or 2D laser triangulation, chromatic confocal measurement processes, or 2D and 3D vision solutions are used in a wide assortment of industries and can make a valuable contribution to quality assurance, cost savings, and, as a result, growing profits. Displacement measurement sensors achieve precision detection, spotting even the tiniest material faults and micro-cracks. Besides the compact housing design (which means the system takes up less space), the various configuration options and simple commissioning process are two added benefits. If you need to record and monitor additional aspects such as diameter, surface area, or volume, then 2D or 3D vision sensors from SICK are the ideal

choice, not just thanks to their wide array of adjustment options. The combination of various types of technology brings its own benefits: For instance, displacement measurement sensors make sure that electronics cards are in the right position. 2D vision sensors measure hole diameters with a high level of accuracy before 3D vision sensors then determine the height and volume of the electronics cards, making it easier to locate shape defects. (tm)

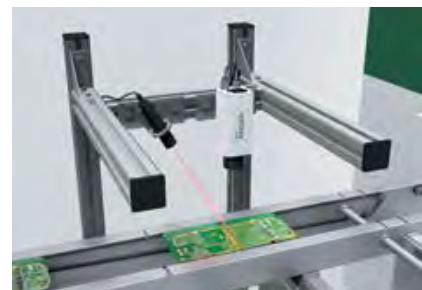

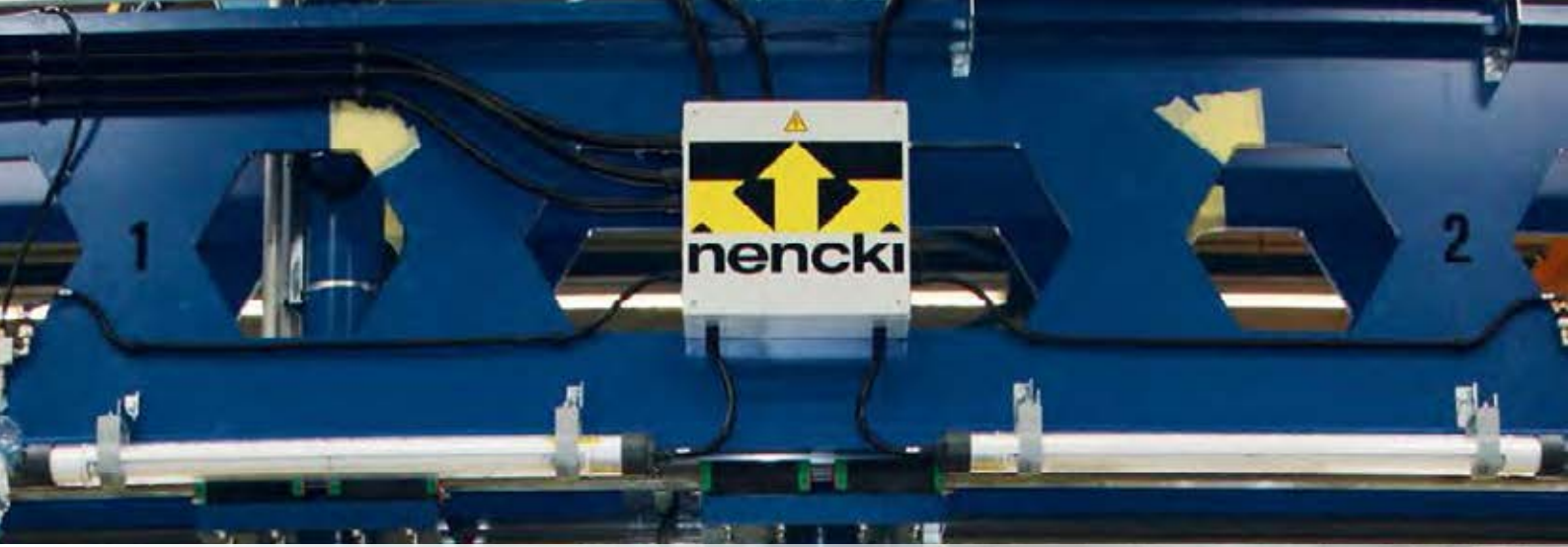

ETHERCAT® INTERFACE SIMPLIFIES INTEGRATION OF WIRE DRAW ENCODERS

PERFECT TEST STAND PRECISION

The Langenthal-based company Nencki AG is very meticulous when it comes to their bogie test stands. By using BTF08 HighLine wire draw encoders with an EtherCAT® interface and OD displacement measurement sensors, they can ensure that test criteria such as suspension stroke and wheel shoulder distance can be measured with absolute precision during final testing.



>> The high resolution means that both the OD Value and OD Mini displacement measurement sensors and the BTF08 wire draw encoder with an EtherCAT® interface can measure distances, deflections, and positions precisely, to within a fraction of a millimeter. However, the main advantage of the EtherCAT® encoder is that it can be seamlessly integrated into the bogie test stand's Beckhoff controller. This saves Nencki from having to implement additional cabling and also allows for extensive diagnostic options – a feature highly valued by many customers.

Nencki test stands – ensuring train and tram safety

Nencki AG is a Swiss family-run company, active in the vehicle and plant engineering sector and also one of the world's leading manufacturers of test stands for bogies in the field of railway technology. "The test stands are used by rolling stock manufacturers and maintenance and repair companies who work on trains, local transport, and underground systems. They are used to test and adjust the wheel loads and geometry of new, repaired, or serviced bogies based on specific requirements," explains Josef Bieri from SICK in Stans, Switzerland, who supervises the project as Account Man-

ager. To achieve this, hydraulic cylinders simulate various vehicle weights and the forces which act upon the bogie during motion, movement around bends, and side winds. The accurate adjustment of, to name but a few examples, distances, spacing, axle parallelism, wheel positioning and alignment, as well as suspension stroke and other parameters, optimizes driving comfort and minimizes wear and operating costs. Most importantly, this makes sure that trains and trams remain on the right track. Measurement, tolerance, and calibration data, collected, for example, whilst measuring the wheel shoulder distance with displacement measurement sensors, is recorded and can be accessed at any time.

Primary suspension testing with wire draw encoders from SICK

Nencki develops bogie test stands, such as the NBT Coach model for metro maintenance workshops, the SBB (Swiss federal railway), or high-speed trains traveling up to 350 km/h, from modular components and adapts them to suit the specific requirements of the customer. One of the key functions is the ability to ascertain and set equal load distribution for each wheel. According to Stephan Gudde from Nencki, this involves measuring each wheel's load and establish-

ing the primary suspension stroke using a total of four BTF08 HighLine wire draw encoders from SICK. The winding mechanism is stored in rugged metal housing. Dirt-repellent brush attachments on the wire input prevent dirt and dust from entering the mechanism. The encoder is used as a stroke measurement element and installed on the external part of the shaft of the cable drum using a servo flange. BTF08 encoders are attached to the frame of the test stand with magnets in order to test primary suspension. The encoder has a threaded loop which is attached to rods positioned in the upper part of the bogie. During the test procedure, the wire draw encoder measures changes in suspension stroke that occur as a result of influential forces, in terms of both distance and height. This must be accurate to within ± 0.1 mm. Suspension stroke and wheel load measurement results are used to automatically calculate whether the primary suspension of a specific wheel requires recalibration. This is accomplished by removing or adding washers, which harden or soften the suspension. The required

The BTF08 wire draw encoder measures changes in the suspension stroke with an accuracy of ± 0.1 mm.



In order to detect load levels and make sure they are even, Nencki uses four BTF08 HighLine wire draw encoders.



thickness of these washers is displayed on the test stand screen.

Encoder interface expertise by SICK

Whilst the outlined measurement procedure has already proven successful in a number of test stands, Nencki required an encoder solution which could be directly integrated into the Beckhoff controller. "Thanks to our wide encoder interface portfolio, in this instance we were able to provide an appropriate solution featuring an EtherCAT® interface," explains Carell Gerig, Application Engineer at SICK in

Stans. In fact, SICK's portfolio of single and multiturn encoders, as well as motor feedback systems, currently supports more than a dozen core interface standards in the field of industrial communication. The portfolio ranges from incremental interfaces, interface technology developed in-house, such as SSI, HIPERFACE®, or the HIPERFACE DSL® single cable technology, and fieldbus systems for production automation, such as DeviceNet, Profibus, and CANopen. On top of this, users can also use Ethernet-based fieldbuses, such as EtherNet/IP, PROFINET – and

EtherCAT®. For Nencki, the implementation of the BTF08 wire draw encoder with an EtherCAT® interface means a significant reduction in integration measures. "We no longer need separate cabling," explains Stephan Gudde. "What's more, the encoder can be programmed from directly within the controller's configuration interface, which considerably simplifies and speeds up the setup process." Furthermore, a fieldbus integration opens up a wide range of diagnostic options which lower the encoder's risk of failure and thus further optimize test stand performance. "This allows us to monitor encoder temperature, for example," explains Josef Bieri. "If one of the specified minimum or maximum values is met, the encoder notifies the control unit directly of any potential critical operational statuses." Fieldbus interfaces can also be used to add additional parameters to the diagnostic process, such as operating hours, programmable position thresholds as well as speed and revolutions.

Displacement measurement sensors in action.



Ensuring safe travel on all routes – with displacement measurement sensors and EtherCAT® wire draw encoders from SICK, Nencki is sure to stay on track. (tm)

 More about the customer at:
www.nencki.ch

OLV LINEAR MEASUREMENT SENSOR

LENGTH AND SPEED – OPTICAL RECORDING, PRECISE CONTROLLING

Non-contact length and speed measuring for any material – not a problem for linear measurement sensors. That is because the non-contact OLV measurement system is an impressive, flexible alternative wherever slippage, vibrations, and wear cause tactile measuring wheels, measuring rollers, or tachometers to generate measurement errors and damage.

>> Linear measurement sensors' principle of operation is based on laser-Doppler technology. This involves a striped pattern being generated on the measured object by two laser beams ①. The movement of the object surface ③ modulates the intensity of the light picked up by the detector ②. The frequency of this modulation corresponds to the laser-Doppler frequency. The light picked up by the detector is transformed into a signal, which a digital signal processor (DSP) uses to calculate the speed and path length.

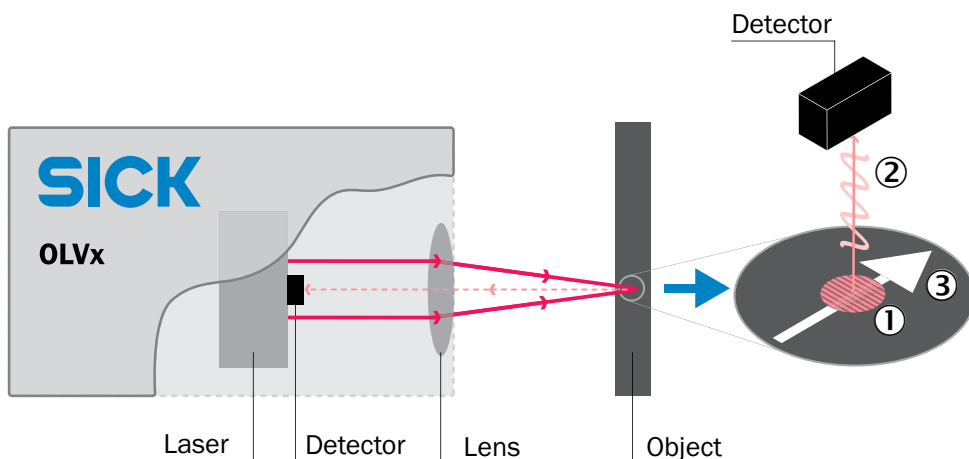

Flexible use

One of the benefits of laser-Doppler technology: You do not need to use any special markers on the measured object. Combined with the high level of ruggedness and simple operating concept, this means that the technology can be used in a wide array of applications:

Tire and rubber industry

The OLV product family can be used for velocity synchronization tasks, among other things, due to its accurate speed and length measurement. This makes it possible to achieve consistent material quality (e.g., profile thickness) and control cutting processes for tire production machinery (extruders).

Steel industry

The OLV sensor product family offers reliable speed measurement for manufacturing products such as steel rods, sheet steel, wire, or pipes – even on hot material surfaces up to 1100 °C.

Printing and paper industry

Length measurement (for example, for incoming goods and pre-delivery inspection) and velocity or differential speed measurement (using two sensors) belong to the OLV product family's scope of application as well as slip detection and control of cutting and pressing processes. (tm)

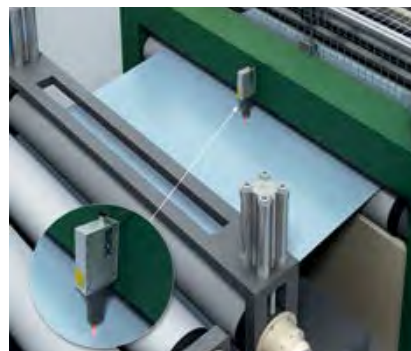



INTELLIGENT ADDITIONAL FUNCTIONS WITH BULKSCAN®

SEAMLESS PROCESSES THANKS TO RELIABLE VOLUME FLOW MEASUREMENT

The Bulkscan® LMS511 laser volume flowmeter by SICK measures bulk materials on conveyor belts and is reliable, non-contact, and maintenance-free, making it a great alternative to traditional belt scales. Thanks to intelligent additional functions like monitoring for the conveyor belt position, load position, and level, the Bulkscan® helps to optimize processes and can warn you of potential damage to the plant.

>> Belt scales weigh the bulk materials. However, the spacing between the material is not always the same. Temperature, moisture, and other factors can increase the volume. In practice, this can result in problems if the bulk materials exceed the volume capacity for the plant or any downstream processes. The material backs up and the process is interrupted as downstream machines become blocked. This is particularly annoying if the machines and conveyor belts sustain damage from overloading.

With its laser-based volume measurement function, the Bulkscan® by SICK is a safe and efficient solution. By conducting direct measurements with a laser, the Bulkscan® scans the contours of the conveyor belt from above. This allows it to determine the cross-sectional area of the bulk materials using the contours of the scanned material. Combining this with the speed of the conveyor belt, the Bulkscan® calculates the volume. The sensor uses the volume measurement to optimize the production process and increase the quality of the processes.

Rugged and reliable – even in extreme weather conditions

Mines not only place huge demands on people, they can also pose a major challenge for machines: Dust, wind, weather, and major temperature fluctuations put strain on the technology. Downtime is factored in from the start, causing costs to rise. Particularly in conditions like this, reliable and precise measurement is important for maintaining the production process.

Thanks to the multi-echo technology from SICK, the Bulkscan® provides precise

measurements, even under the harshest of weather conditions. The volume flow sensor can also tackle poor visibility without any problems. The Bulkscan® is designed for maintenance-free operation: Thanks to its rugged housing and built-in heating function, it requires no maintenance when used outside – even at temperatures from -40 to +60 °C.

Process optimization thanks to intelligent additional functions

The mining industry often requires rough material to be transported. However, belt scales only detect the weight of the bulk materials. This can be a disadvantage as

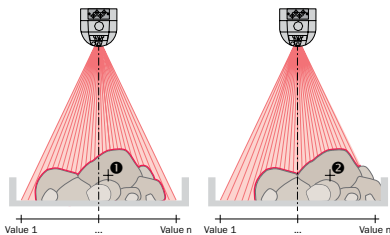

Center of gravity measurement function: The Bulkscan® uses this data to detect one-sided loads or one-sided belt loads.

large lumps of rock can cause blockages in subsequent processes. This is why the Bulkscan® LMS511 not only measures the volume of the bulk materials but also the height profile. Large lumps can be removed from the conveyor belt in good time to prevent blockages in plants further down the line.

The laser volume flowmeter also includes a function for determining the bulk ma-

terials' center of gravity. This function in particular helps to improve system throughput. The Bulkscan® also uses the bulk materials height measurement to calculate the alignment of the products. If the center of gravity sits too far to the right or left of the conveyor belt, the Bulkscan® lets the operator know; after all, having all of the load on one side can cause damage to the conveyor belt. Furthermore, monitoring the edges of the bulk materials prevents the material from falling off the belt.

A conveyor belt that has been displaced will wear out at a fast rate. The sensor's intelligent belt monitoring function therefore emits a warning if the conveyor belt has shifted and detects the loading position and threshold for the bulk materials.

Communicative, backward-compatible and ready for Industry 4.0

Communication with higher-level communication systems is essential for a safe and secure production process. The Bulkscan® uses Ethernet TCP/IP to transmit data in a matter of seconds. Hazards are detected in good time and processes can be optimized quickly, without interrupting the production process. The Bulkscan® can be directly connected to a higher-level PLC, thus allowing fully-functional integration. A simple installation concept means that the sensor is ready for use in a matter of moments. An intuitive user interface also makes the sensor easier to control.

The BAM100 analog module can also read in and output analog current values



Belt monitoring function: The Bulkscan® emits a warning if the conveyor belt has shifted and detects the loading position of bulk materials.

in the range of 4 to 20 mA. In this process, the module converts digital signals into analog ones, or vice versa. Thanks to this backwards compatibility, the laser volume flowmeter can even be integrated into older plants.

As a result, the SICK Bulkscan® is ideal for flexible use. Besides more traditional applications in mining, it is also used in the loading of freight trains. The food industry also relies on the Bulkscan® LMS511. Whether it is measuring potatoes, soya beans, or spinach, varying gaps between the items pose no problem to the flow sensor thanks to its intelligent volume measurements. (fd/tm)

MEASUREMENT TECHNOLOGY THAT'S ON YOUR SIDE

NEW MASTER PLAN FOR MERCURY EMISSIONS FROM LARGE COMBUSTION PLANTS

Will Europe soon have similar mercury emission limit values to America? The impending updates to the BREF documents have indicated that mercury emissions from large combustion plants will soon have to be reduced dramatically. However, a reliable measurement solution is already ready and waiting with a certified measuring range from 0 to 10 $\mu\text{g}/\text{m}^3$ of mercury. The MERCEM300Z by SICK.

>> In the field of emissions monitoring, mercury (Hg) is one of the elements that is moving further and further into public focus. And mercury emissions are far from being a local issue; this problem affects every corner of the globe. The mere fact that gaseous mercury stays in the atmosphere for more than six months and therefore crosses the entire globe, making its way into our eco-systems, has galvanized a number of protection organizations and environmental authorities. Even the United Nations has got involved, declaring the reduction and prevention of mercury emissions as a top priority and setting up the UNEP

environment program to establish a global, legally-binding convention on reducing harmful and polluting mercury emissions.

New limit values for mercury emissions

Large combustion plants have also found themselves in the spotlight – this refers to industrial plants with a rated thermal input of 50 megawatts and above and which are used to convert energy from fossil and biogenic energy sources. It is not yet fully clear how strict the mercury emissions limits for large combustion plants in Europe will be. This will be published in the updated LCP BREF (Large Combustion Plant Best Available

Techniques Reference Document), a document prepared by the European Commission which describes the best available technology (BVT) for each field of industry in a bid to prevent and reduce environmental impact. Forecasts believe that the average annual Hg emission limit values for hard-coal fired power plants in Europe will be reduced to between 1 and 4 $\mu\text{g}/\text{m}^3$ and to between 4 and 7 $\mu\text{g}/\text{m}^3$ for lignite power plants. These emission hard-coal fired power plants will then apply to both new and existing power plants. The current limit values for Europe are between 30 $\mu\text{g}/\text{m}^3$ and 50 $\mu\text{g}/\text{m}^3$. The USA is currently leading the field with mercury limits of around 1.5 to 2.3 $\mu\text{g}/\text{m}^3$ for coal-based power plants. However, unlike the annual average used in Europe, this figure is based on a 30-day average.

Best available measurement technology

The BREF documents describe the best available technologies and consumption data alike, making them a reference for authorities across Europe when approving industrial plants. So how well equipped are plant operators in terms of the measurement technology needed to adhere to the new limit values and safely monitor their mercury emissions?

“If they are in fact going to be ratified and implemented within the EU, the limit value targets set out in the current BREF documents are a huge leap forward when it comes to reducing mercury emissions,” says Florian Greiter, Product Manager at SICK. “It will all boil down to power plants investing in improved gas purification methods and even more accurate emission measurement technology. We have everything that power plants need to tackle these new challenges: the MERCEM300Z mercury gas analyzer.”

MERCEM300Z



The MERCEM300Z was designed especially for monitoring total mercury emissions in flue gases.

Thanks to its patented direct measurement technology, the system meets all current official requirements as well as those currently in the preparation stages. The built-in adjustment cell (which is the only one of its type in this field) allows for fully automated drift tests along with optical system adjustment. This feature has a number of benefits, not least of which is the reliable delivery of measured values with long term stability. The optional built-in test gas generator enables operators to conduct comprehensive system and functional checks. SICK's popular operating concept and the modern communication protocols are the perfect finishing touches to the MERCEM300Z's profile, making it a sophisticated mercury measurement system that is easy to integrate, easy to use, and stable on a long term basis.

“The limit value targets set out in the current BREF documents are a huge leap forward when it comes to reducing mercury emissions.”

Florian Greiter, Product Manager at SICK

The MERCEM300Z is a continuous analyzer with the lowest certified measuring range of 0 to 10 $\mu\text{g}/\text{m}^3$ so that it is ready and waiting to tackling the mercury measurement needs of tomorrow. Its large range means that it can even tackle measuring ranges from 0 to 1,000 $\mu\text{g}/\text{m}^3$, making it ideal for raw gas measurements. Because everything needs checking and testing, it has been tested for suitability in accordance with EN 15267.



The MERCEM300Z accurately detects Hg concentration in raw gas.

In the EU, suitability testing is always carried out on two identical systems and consists of a lab test with subsequent field tests. A suitability test for a 1-component CEMS (continuous emission monitoring system) lasts between 6 and 14 months in total. During the field tests, the analyzer is required to prove its compatibility in waste incineration plants, cement plants, and power plants.

It is not particularly easy to draw comparisons between measurement requirements and limit values in Europe and the

USA. In the USA, each individual CEMS is tested according to Performance Specification 12A (PS 12A) within the first few weeks after commissioning. Certification prior to commissioning, which is what happens in a suitability test, does not take place. The two regions also differ in that mercury emissions in the USA have to be monitored as a monthly average instead of as a daily mean. SICK has already delivered a number of MERCEM300Zs to the USA. These have been successfully calibrated according to PS 12A and can even monitor mercury emissions below 1 $\mu\text{g}/\text{m}^3$.

Groundbreaking mercury measurement

Additional measures must be incorporated into plant processes if the more stringent limit values are to be complied with over the long term. With the MERCEM300Z, plant operators can detect unpredicted Hg peaks during the combustion process at an early stage. Taking measurements in the raw gas before the scrubber also has its benefits: Measures to reduce Hg levels can be applied immediately so that there are no nasty surprises in the stack at the end of the process. Furthermore, the operator is also able to check and cut costs by adding exactly the right amount of activated carbon and coagulant to the raw gas. The MERCEM300Z is even equipped to deal with the high dust loads and higher concentration of inter-

fering compounds that occur in the raw gas. As a result, it delivers quick and reliable measurement results at all times. Due to its low-maintenance design and simple operating concept, it can monitor mercury concentration in the long term and with a high level of measurement certainty.



The MERCEM300Z monitors Hg emissions with a high level of availability in accordance with official national and international requirements.

The MERCEM300Z is an analyzer for gaseous total mercury (elemental and oxidized mercury) used to monitor emissions and control mercury separation in raw gas – in power plants, cement plants, and waste incineration plants. It is also available in variants for outdoor use or for use in temperature-controlled rooms. (sh)



SENSOR TECHNOLOGY FOR ELECTRIC ARC FURNACES

WHO ANALYZES WINS

SICK supplies sensor solutions for almost every possible application in the metal and steel sector, even in the world of analytical measuring. The company's latest innovation is METPAX300, a customized analyzer system which measures exhaust gas emissions from electric arc furnaces.

>> The vast majority of structural steel, high-quality steels, and stainless steels manufactured in electric arc furnaces (EAF) are produced by melting down steel scrap for reuse. This process consumes less energy than producing steel via the blast furnace route. However, in both cases, the ambience is dominated by dirt, heat, vibrations, and noise. These prevailing conditions mean that it

is often difficult for measuring technology to be both failsafe and precise. Yet the use of reliable measuring technology is essential in order for production to run more cost-effectively, for climate protection targets to be achieved, and to increase flexibility and safety.

The measuring tasks to be carried out at an electric arc furnace are many and

varied. The reliable sensor technology from SICK is used in a whole range of applications to help report dangers and faults in good time: when scrap is being fed in, in the furnace burner itself, and even in ladle handling. Consumption levels for both oxygen and natural gas, for example, must be monitored directly at the furnace. Similarly, fuel pressure and the temperature also have to be moni-





tored, as does the inertization of fuel and oil tanks. And, very importantly: Exhaust gas measurements have to be taken.

A systematic approach to measuring exhaust gas

Cost-effective precision control of carbon injection, oxygen injection, and burner configuration settings relies to a high extent on the exhaust gas emissions from an electric arc furnace being analyzed accurately. The gas matrix is incredibly difficult to calculate due to the use of DRI (direct reduced iron), HBI (hot briquetted iron), and pig iron or hot metal in electric arc furnaces in addition to different grades of scrap. This varied mixture manifests itself as sticky mud and thick dust in exhaust gas. With all of this happening at an exhaust gas temperature of up to 1,700 °C, team work is the order of the day if the composition of the gas is to be identified under such conditions. The MCS300P process gas analyzer, the TRANSIC100LP laser oxygen transmitter, and the METPRO gas sampling probe for high levels of dust concentration make a winning team. Installed in a stainless steel cabinet and forming a reliable low-maintenance system, the analysis technology combines to form METPAX300, the new customized analyzer system by SICK.

Detecting CO, CO₂, H₂O, O₂, METPAX300 accurately analyzes the composition

of the exhaust gas. The water-cooled METPRO probe takes exhaust gas from the exhaust gas line directly after the electric arc furnace. A portion of the exhaust gas flows through the innovative cross-flow filter, which has been optimized by SICK specifically for this application. Freed of dust, the gas then flows through a heated measuring gas line to the MCS300P process gas analyzer and on to the TRANSIC100LP for oxygen measurement. The hot measuring technology of the MCS300P means that there are no problems with condensation while, at the same time, its ability to measure humidity means that leaks affecting water-cooled components of the EAF can also be detected. The process gas analyzer takes measurements directly of the original gas. The analyzer cabinet is designed specifically for heavy duty requirements: Vortex coolers driven by compressed air continually cool and flush its interior. The cooling air flow is introduced from the inside to the outside. Dust ingress is thus prevented, as is overheating.

METPAX300 for clarity

By analyzing exhaust gas, plant operators can draw conclusions about slag quality from the measurement of the ratio of CO to CO₂ and O₂. The result of the analysis provides information on the carbon content in the heat based on the measurement of the ratio of CO to CO₂.

It reduces energy consumption by enabling O₂ injection and CO combustion in the furnace to be optimized. It also allows the burners and carbon injection lances to be fine-tuned for the injection of oxygen and carbon by setting the ratio of CH₄ to O₂ for the wall burners, as well as helping to avoid explosions and preventing furnaces from bursting as a result of too much CO content in the exhaust gas or water leaks.

Recognized quality

Only high-quality hardware which delivers consistent measuring quality can attempt to take on this challenge. To put this to the test, the system was put through its paces for a period of 18 months at Hellenic Halyvourgia, a steelworks in Greece. The test reports show that the METPAX300 analysis system is able to deliver both reliable measurement results and operational safety. Both criteria – reliability and operational safety – are the basis upon which processes can be optimized and precision-controlled. They are also crucial to long-term seamless operation.

More than satisfied, the customer is taking ownership of the system following successful completion of testing. (sh)

 More about the customer at: www.hlv.gr

CUSTODY TRANSFER MEASUREMENT OF NATURAL GAS

FLAWSIC600-XT: THE PERFECT MATCH

FLAWSIC600-XT – the new gas flow meter from SICK seamlessly preserves its predecessor's positive image as an outstanding precision measurement device for demanding industrial environments. The FLOWNIC600-XT stands out from the crowd following its customer-oriented makeover. The product family concept is made up of various versions, making it easier to find the right device. As a result, you always have the right XT for the task at hand.

>> These days, lower oil prices no longer cover costs, meaning that an increasing number of companies in the oil and natural gas industry are now finding themselves in hot water. An issue even closer to our hearts is the fact that these companies also pass these pressures onto manufacturers of measurement technology. And we are not just talking about prices anymore. The pressure is now on improving the quality of devices and guaranteeing high-precision measurements. Gas flow meters for custody transfer measurements are also affected by this problem, with the users themselves leaving no room for compromise in this situation. Measurement technology has to guarantee long-term stability with even lower measurement uncertainty, as well as being simply reliable. After all, measurements that are incorrect by just a tenth of a percent can quickly add up over longer periods, leading to huge losses in quantity calculations. In light of this, demand for user-friendly gas flow meters is rising, along with the need

for simple calibration, commissioning, diagnostics, and speedy service should worse come to worst. Time is always money.

The latest development

The FLOWNIC600-XT has the answer to this trend in gas flow measurements. The new gas flow meter from SICK is available in four variants, either as individual or system solution, and can conquer complicated tasks that call for precision custody transfer measurements of natural gas. In doing so, the FLOWNIC600-XT builds on the popular strengths of its predecessor, continuing to be rugged, reliable, and precise. Users enjoy the positive factors that come from using ultrasound to measure the flow of natural gases. This technology can record accurate measurements while remaining largely unaffected by the properties of natural gas, making it particularly well suited to custody transfer measurements. Despite pressure fluctuations, vibrations,

and dirt particles in the gas flow, the FLOWNIC600 gas flow meters stand out from other methods time and again thanks to their transit-time difference technique in the direct path layout. There are no mechanical parts that can be worn down and no contamination to affect the quality of the signal, as is the case in ultrasound measurements using the reflection method.

Using cutting-edge ultrasonic sensor technology and more efficient electronics, SICK has managed to provide users with even more benefits. The additional XT gene in the FLOWNIC600-XT combines the unique user-friendly design with stripped-back simplicity. This takes the FLOWNIC600-XT up to the next level and creates an even more convenient and safer environment for measurements.





The compact installation requirements make installing the FLOWSIC600-XT Forte even easier while reducing installation costs at the same time. As a result, it is ideal for use in areas such as offshore platforms or in compact measurement stations.

From better to the best

Background noise is a real poison for accurate ultrasonic measurements. Expansions in pipelines, valves, plant vibrations, or pressure regulators often cause critical levels of noise for the ultrasonic measurement process. Though we humans would never hear the difference, they can have a huge impact on ultra-

sonic sensors. These noises can affect the way signals are received, particularly in the high frequency range between 85 and 200 kHz. This in turn can affect the signal quality, leading to uncertain measurements. With new ultrasonic sensors and optimized electronics, SICK has managed to improve the system's resistance to disruptive noises in the application. Noises no longer have a negative impact on measurements.

Does the pressure or temperature of the gas change in the application? The built-in pressure and temperature sensor measures this and supports the automated calculation of minimal geometric changes to the meter in a bid to improve the accuracy of the measurement result.

Thanks to the new i-diagnostics™ function, the FLOWSIC600-XT can monitor itself. If changes to the plant status are detected, for example as a result of contamination, moisture in the gas, or disruptive noises, the FLOWSIC reports them straight away and the solution wizard in the new, intuitive FLOWgate™ operating software provides speedy assistance.

And the best thing? Thanks to the PowerIn Technology™, the FLOWSIC600-XT continues measuring even in the event of mains voltage failure. The amount of power required by the entire electronics system is reduced and the built-in backup battery supplies the power instead, lasting as long as three weeks. Now,



Pressure regulation station with the FLOWSIC600-XT Quatro and FLOWSIC600 at terranets bw.



Gas storage with the FLOWSIC600-XT and FLOWSIC600.

there is no need to fall back on other measurement techniques in the event of a mains voltage failure.

Put to the test

SICK has created a gas storage application to show the world that the FLOWSIC600-XT meets the high standards set by its predecessor. The FLOWSIC600-XT was installed in series with the FLOWSIC600 for testing, which turned out to be very successful: both devices achieved outstanding synchronization.

To demonstrate the improved resistance to disruptive noises, SICK installed the FLOWSIC600-XT Quatro with two redundant measurement systems using various ultrasonic sensor frequencies directly in front of a pressure regulating valve in a plant. This type of plant is typically used for transporting natural gas and controlling natural gas distribution systems in cities. This application demonstrated just how good the quality and electronic optimization really are.

Plus an innovative design

These tests and the initial installations show just how easy it is to incorporate the FLOWSIC600-XT into systems. On top of that, the iF DESIGN AWARD 2016 has confirmed that the quality and precision of the FLOWSIC600-XT are also reflected in its appearance. An international jury of experts presented SICK and the FLOWSIC600-XT this award for its innovative design and impressive recognition factor in February 2016. (sh)

SICK REPAIR SERVICE

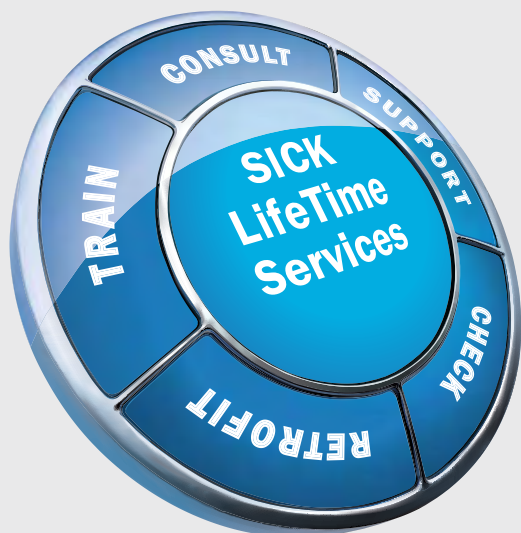

FLAT RATE

From fault analysis to measurement device repairs: The repairs flat rate for gas analysis and dust measuring devices by SICK gives you added security and makes it easier to plan costs and repair times. This service is also more cost-efficient than buying new or exchange units. The warranty is extended to the fault-free operation of the repaired device because the device undergoes a general overhaul during every repair session and assemblies, consumables, and wear parts that affect functionality are replaced. This approach aims to prevent future failures. This service also includes testing the measurement certainty and calibration under laboratory conditions. Quick and reliable repairs – a new lease of life for your measuring devices. (sh)



SICK AppSpace: GIVING SPACE TO YOUR IDEAS AND SOLUTIONS.

THIS IS **SICK**

Sensor Intelligence.

Break through the boundaries of conventional programming – with SICK AppSpace, SICK's open platform for programmable sensors. The SICK AppSpace eco-system offers system integrators and original equipment manufacturers (OEM) the freedom and space to develop application solutions to fit the specific requirements of application descriptions. From precisely designing the perfect online user interface, through selecting the most suitable programming technique to distributing the software on various hardware platforms, for SICK AppSpace, one thing is of paramount importance: Providing you with flexibility during the development of a customized solution. We think that's intelligent. www.sick.com/SICK_AppSpace

Visit us online:
www.sickinsight.com

SICK

Sensor Intelligence.

SICK AG

Erwin-Sick-Str. 1 | 79183 Waldkirch | Germany
Phone + 49 7681 202-0 | Fax +49 7681 202-3863

www.sick.com

Order No. 8019230

